

Cornici



Le Cornici / The Frames



FALPA

LA FALPA NASCE NEGLI ANNI '50 COME DITTA INDIVIDUALE FONDATA DA GUIDO GORI. COMINCIA AD INTERESSARSI ALL'ARTE ALL'INIZIO DEGLI ANNI '60 ACQUISTANDO E VENDENDO OPERE DI ARTISTI LOCALI. CRESCE NEGLI ANNI L'INTERESSE, SI INSERISCONO NUOVE PROPOSTE, SI DÀ SPAZIO ALLE OPERE PITTORICHE IN UNA NUOVA SALA ESPOSITIVA E SI RAGGIUNGONO MERCATI SEMPRE PIÙ AMPI. TUTTO CIÒ GRAZIE ALLA VIVACITÀ E CREATIVITÀ DEI NOSTRI ARTISTI, A QUANTI LI APPREZZANO ED ALLE MOLTE "VETRINE" CHE SI SONO APERTE PER LORO IN TANTE CITTÀ SUL NOSTRO TERRITORIO E NEL MONDO.



FALPA

FALPA WAS BORN IN THE FIFTIES' AS A ONE-MAN BUSINESS FOUNDED BY GORI GUIDO. IT STARTED TO BE INTERESTED IN ART AT THE BEGINNING OF THE SIXTIES' BUYING AND SELLING PAINTINGS OF LOCAL ARTISTS. THE INTEREST HAS INCREASED IN THE YEARS, NEW ARTISTS HAVE ENTERED IN THE BUSINESS, SPACE HAS GIVEN TO THE PICTORIAL PAINTINGS IN A NEW SHOW-ROOM AND LARGER MARKETS HAVE BEEN ACHIEVED. IT HAS HAPPENED THANKS TO THE VIVACITY AND CREATIVITY OF OUR ARTISTS, TO WHOM APPRECIATES THEM AND TO THE MANY "WINDOWS" THAT HAVE BEEN OPENED FOR THEM IN MANY CITIES IN OUR COUNTRY AND IN THE WORLD.



LE CORNICI/THE FRAMES

"I QUADRI VIVONO NELLE CORNICI.
QUESTA ASSOCIAZIONE DI QUADRO E CORNICE NON È ACCIDENTALE.
L'UNO HA BISOGNO DELL'ALTRA.
UN QUADRO SENZA CORNICE HA L'ARIA DI UN UOMO SVESTITO E NUDO.
LA RELAZIONE FRA L'UNA E L'ALTRA È, DUNQUE ESSENZIALE E NON FORTUITA: HA IL
CARATTERE DI UN'ESIGENZA FISIOLÓGICA..." (J.ORTEGA Y GASSET)

GIÀ NELL'ANTICO EGITTO LA CORNICE ERA PRESENTE IN ALCUNI MANUFATTI PITTORICI, CIÒ DIMOSTRA COME L'UOMO ABBA SEMPRES PREFERITO VEDERE UNA PRECISA LIMITAZIONE DELLA SUPERFICIE, RACCHIUDENDOLA COSÌ IN UNO SPAZIO DEFINITO.

LO SCOPO DELLA CORNICE SOMIGLIA QUINDI A QUELLA DI UN LIMITE, OLTRE IL QUALE LO SPAZIO ILLUSORIO SI CREA, AL PUNTO TALE DA FARCI INTUIRE UNO SPAZIO POSSIBILE AL DI LÀ DI QUEL CONFINE.

IL FINE DELLA NOSTRA AZIENDA È QUELLA DI CREARE UN TUTT'UNO CON LO SPAZIO, UN'ORGANICITÀ NELLO STILE, NEGLI EQUILIBRI, NELLE COLORAZIONI E NON PER ULTIMO NELL'UTILIZZO DI MATERIALI. SECONDO L'ESPERIENZA DI PRODUZIONE CINQUANTENNALE DELLA FALPA LA CORNICE DEVE ASSUMERE IL RUOLO DI MEDIATORE TRA PARETE E SPAZIO PITTORICO, COME I PROFILI DI UNA FINESTRA CHE DIVIDONO MA NELLO STESSO TEMPO APRONO LA PORTA ALLA REALTÀ ESTERNA.

LA RICERCATEZZA DI FORME ELEGANTI, A VOLTE SEMPLIFICATE, LINEARI E SOFISTICATE HANNO RESO LA NOSTRA PRODUZIONE ADATTABILE A VARI GENERI PITTORICI, LA VALORIZZAZIONE DELLA PRODUZIONE È DATA DA FINITURE D'ALTA QUALITÀ, PAZIENTEMENTE RIFINITE DA MANI ESPERTE ED IN MODO PRIORITARIO DALL'UTILIZZO DI MATERIALI NOBILI E RICERCATI.



"THE PAINTINGS LIVE IN THE FRAMES.
THIS LINKING BETWEEN PAINTING AND FRAME IS NOT CASUAL.
THEY NEED EACH OTHER.
A PAINTING WITHOUT A FRAME LOOKS LIKE AN UNDRESSED AND NAKED MAN.
THE RELATIONSHIP BETWEEN EACH OTHER IS ESSENTIAL AND NOT CASUAL:
IT HAS THE CHARACTER OF A FISIOLÓGICAL NEED..." (J.ORTEGA Y GASSET)

THE FRAME HAD ALREADY BEEN PRESENT IN THE PAST EGYPT IN SOME PICTORIAL MANUFACTURES; THIS FACT DEMONSTRATES THAT MAN HAD ALWAYS PREFERRED TO SEE AN EXACT LIMIT OF SURFACE, CONTAINING IT IN A DEFINITE SPACE.

THE AIM OF THE FRAME SEEMS LIKE A LIMIT, OVER WHICH THE UNREAL SPACE IS CREATED, SO THAT WE CAN SENSE A POSSIBLE SPACE ACROSS THE BORDER.

THE PURPOSE OF OUR COMPANY IS TO CREATE AN WHOLE WITH THE SPACE, AN ORGANIC UNITY IN THE STYLE, IN THE BALANCES, IN THE COLOURINGS AND NOT LAST IN THE USE OF MATERIALS.

IN THE THIRTY-YEAR EXPERIENCE OF PRODUCTION OF FALPA, THE FRAME MUST ASSUME THE ROLE AS MEDIATOR BETWEEN THE WALL AND THE PICTORIAL SPACE, LIKE THE BORDER LINES OF THE WINDOW THAT DIVIDE BUT IN THE SAME TIME OPEN THE DOOR TO THE OUTSIDE REALITY.

THE REFINEMENT OF ELEGANT, SOMETIMES MADE SIMPLER, LINEAR AND PARTICULAR SHAPES HAVE MADE OUR PRODUCTION ADAPTABLE TO MANY PAINTING GENRES; THE ENHANCEMENT OF THE PRODUCTION IS MADE BY HIGH QUALITY FINISHES, CAREFULLY DECORATED BY EXPERT HANDS AND OVERALL BY THE USE OF NOBLE AND REFINED MATERIALS.

ART. BASCHENIS

FINITURA ARTIGIANALE / HANDCRAFT FINISH



cherna



PAG.7



Batso

FINITURE DISPONIBILI / AVAILABLE FINISH:

1. ART. BASCHENIS ARGENTO / SILVER BASCHENIS

2. ART. BASCHENIS ORO / GOLD BASCHENIS



1.

Cherco

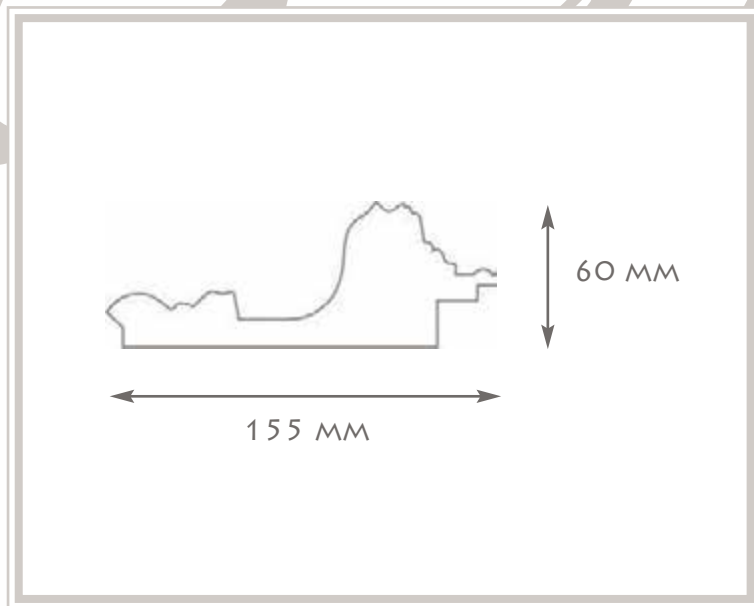

PAG.9



2.



ART. BELLINI

FINITURA ARTIGIANALE

/ HANDCRAFT FINISH

UML



Bella

FINITURE DISPONIBILI / AVAILABLE FINISH:

1. ART. BELLINI FIN. B

2. ART. BELLINI FIN. A

3. ART. BELLINI ORO / GOLD BELLINI

4. ART. BELLINI FIN. D

5. ART. BELLINI ARGENTO / SILVER BELLINI

6. ART. BELLINI FIN. C

1.

2.

3.



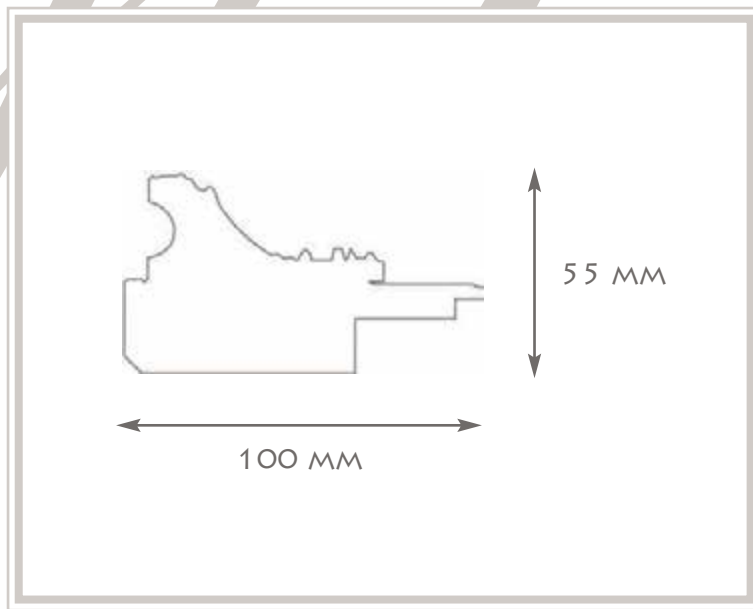

5.

PAG.13

6.

4.



Botticelli
ART. BOTTICELLI

FINITURA ARTIGIANALE / HANDCRAFT FINISH



Accepted



Batt

FINITURE DISPONIBILI / AVAILABLE FINISH:

1. ART. BOTTICELLI ARGENTO / SILVER BOTTICELLI

2. ART. BOTTICELLI ORO / GOLD BOTTICELLI

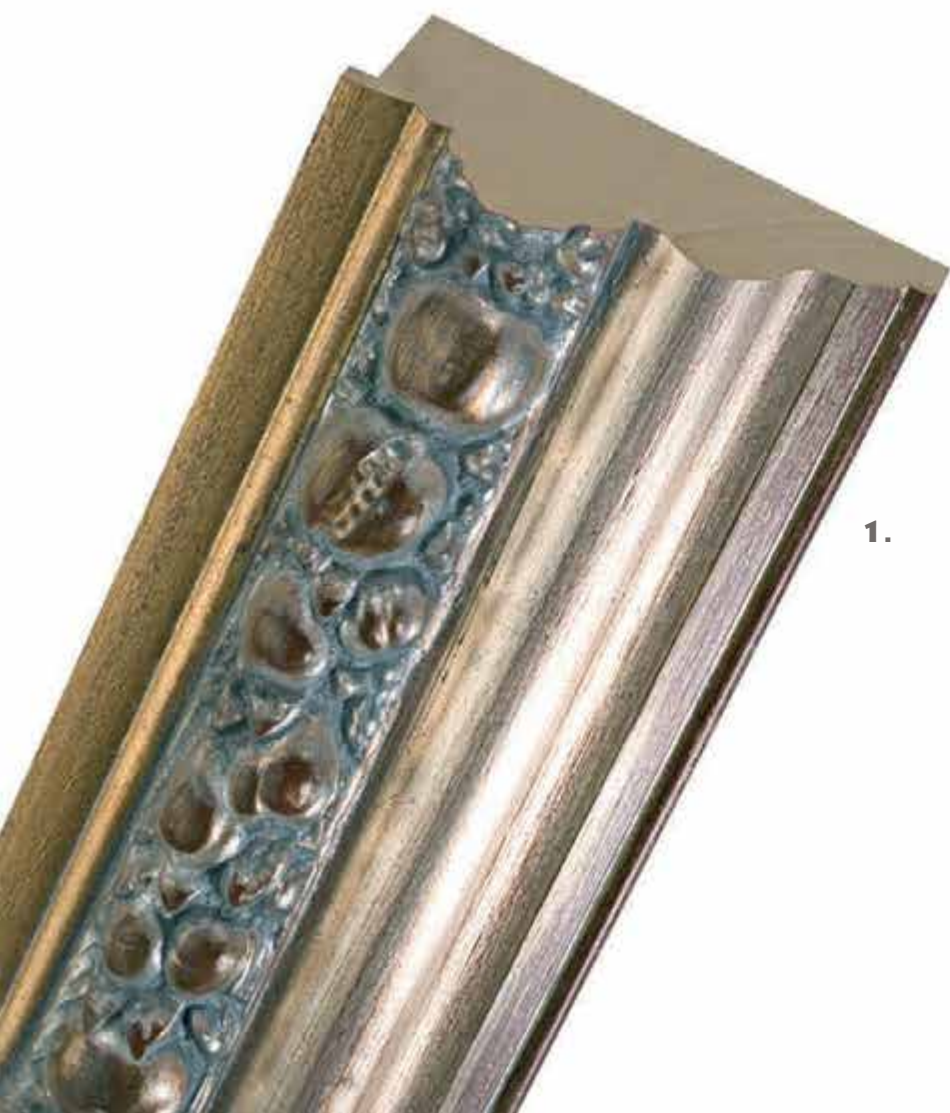

1.

Accepted

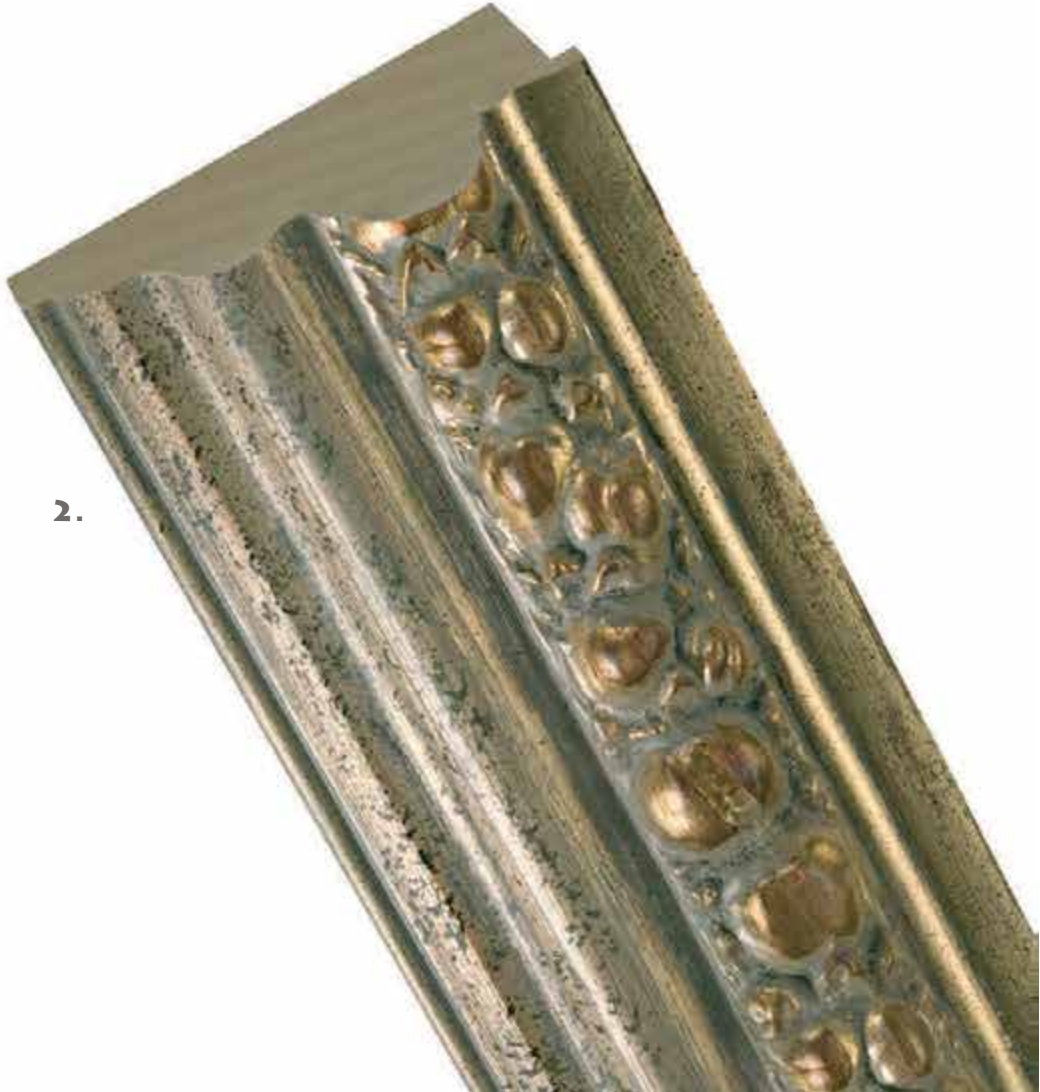
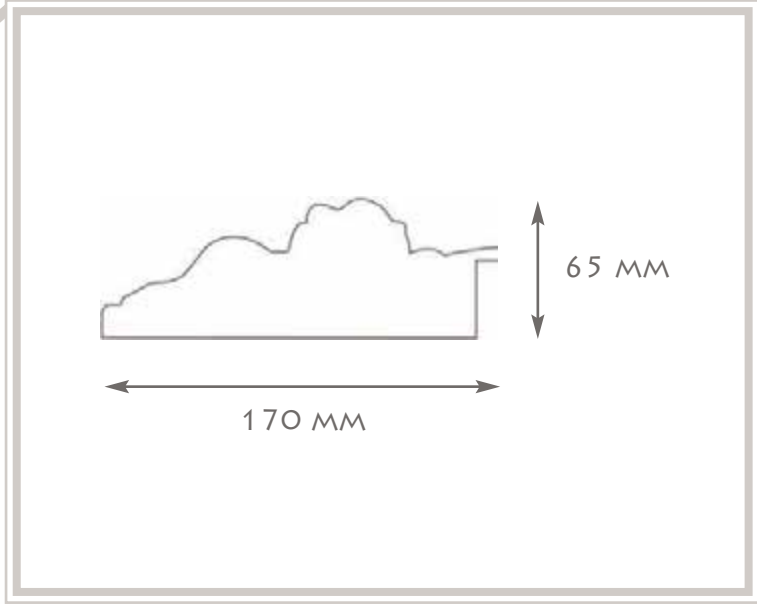

2.

ART. CANALETTO

FINITURA ARTIGIANALE / HANDCRAFT FINISH



at K P t t

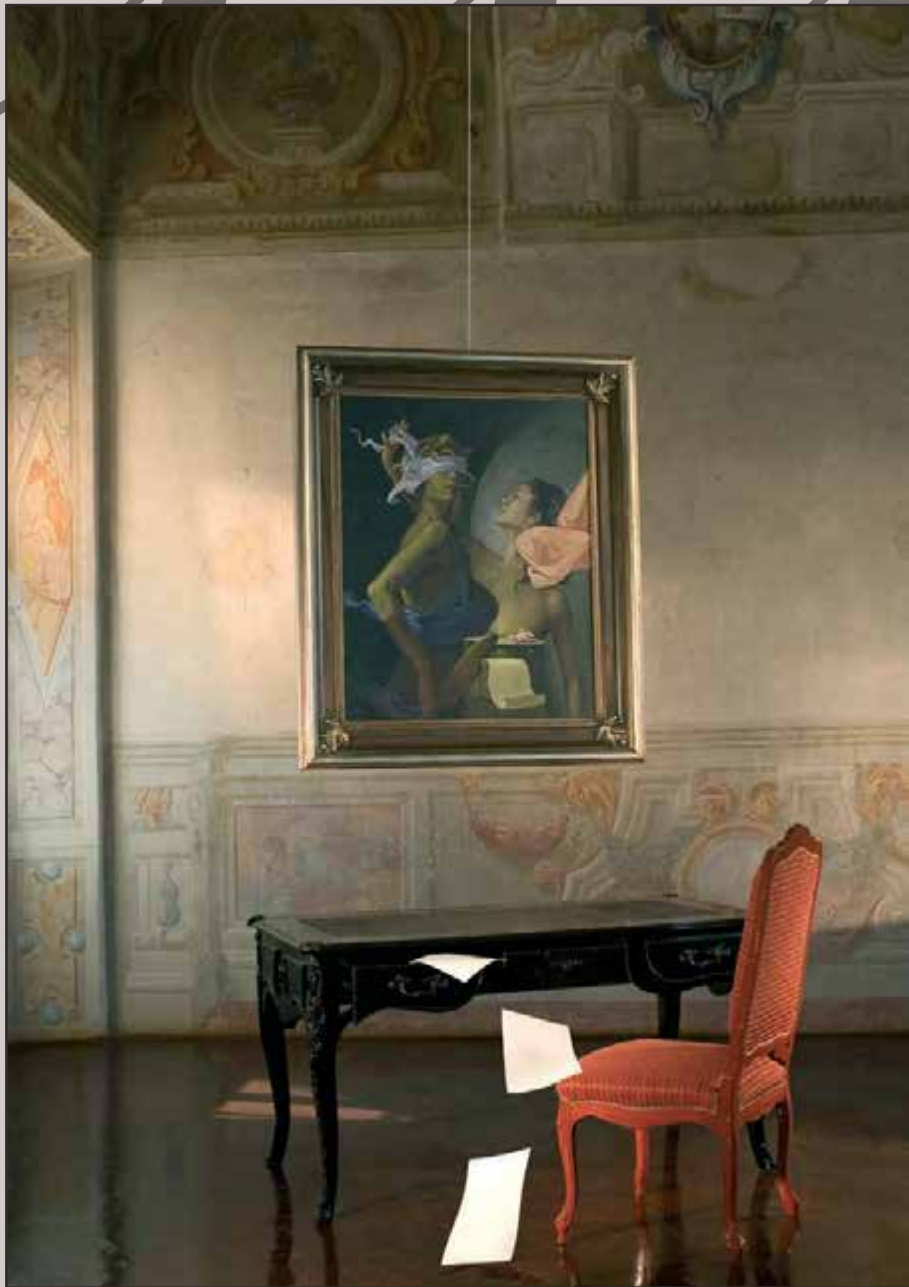

Catena

FINITURE DISPONIBILI / AVAILABLE FINISH:

1. ART. CANALETTO ORO / GOLD CANALETTO
2. ART. CANALETTO ARGENTO - NOCE / SILVER - WALNUT CANALETTO



1.

atKetta

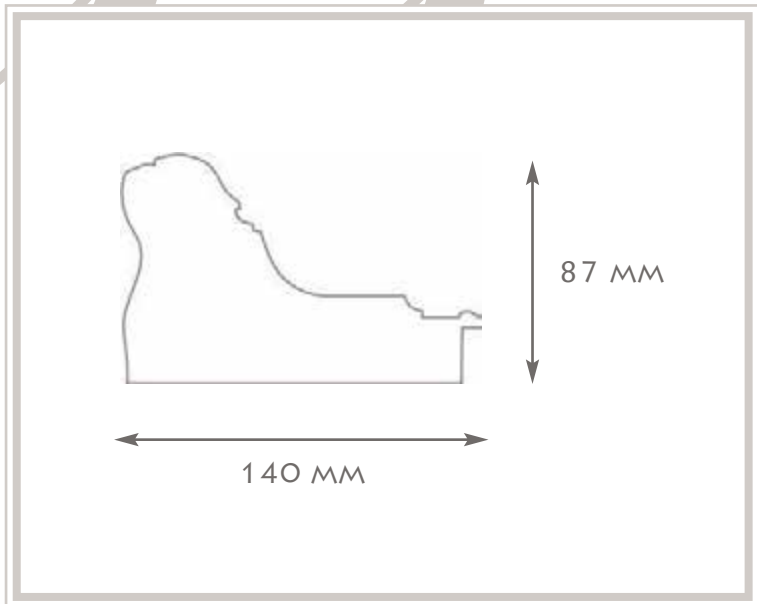

2.

Art. CARAVAGGIO

FINITURA ARTIGIANALE / HANDCRAFT FINISH





Caravaggio

FINITURE DISPONIBILI / AVAILABLE FINISH:

1. ART. CARAVAGGIO ARGENTO PATINATO / PATINATED SILVER CARAVAGGIO

2. ART. CARAVAGGIO ORO / GOLD CARAVAGGIO



1.



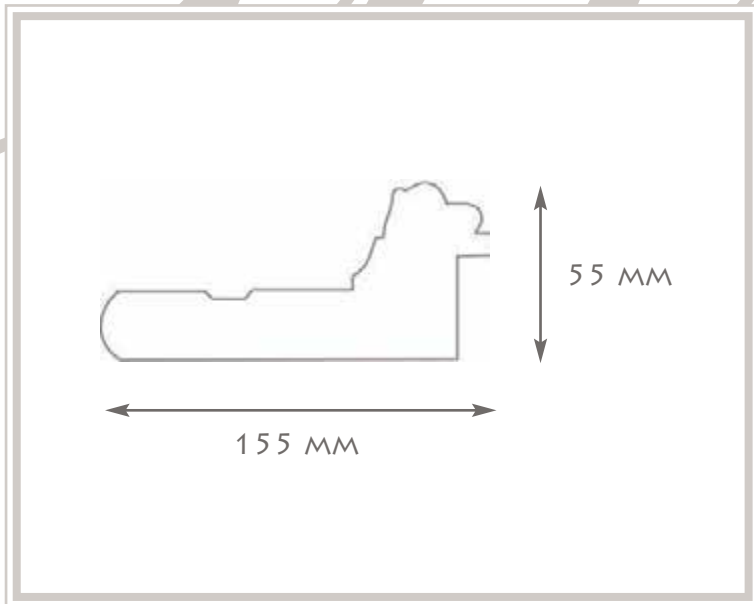

2.

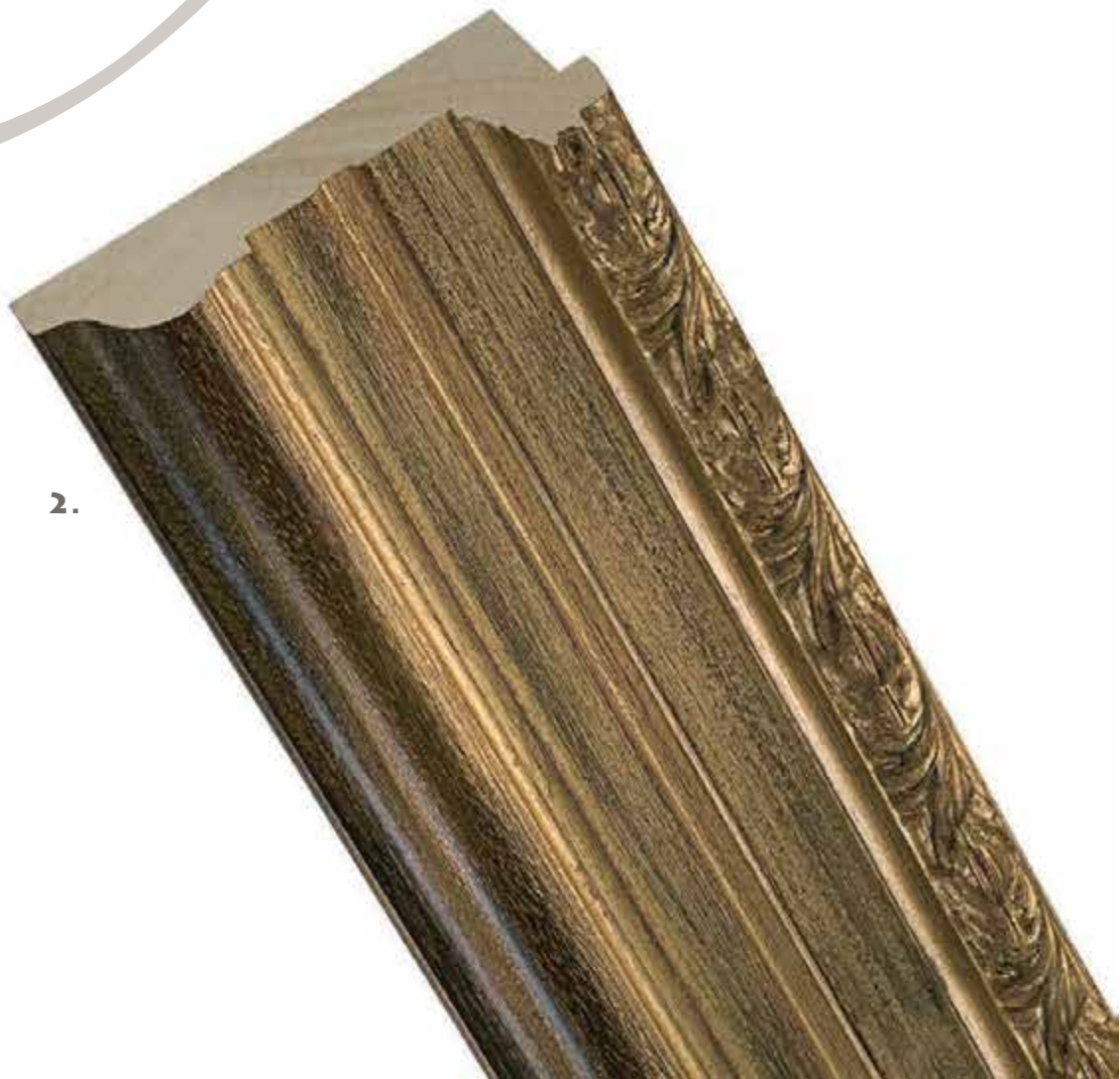

ART. CORREGGIO

FINITURA ARTIGIANALE / HANDCRAFT FINISH



re d d u



Corre

FINITURE DISPONIBILI / AVAILABLE FINISH:

1. ART. CORREGGIO ARGENTO / SILVER CORREGGIO

2. ART. CORREGGIO ORO / GOLD CORREGGIO



1.



readu

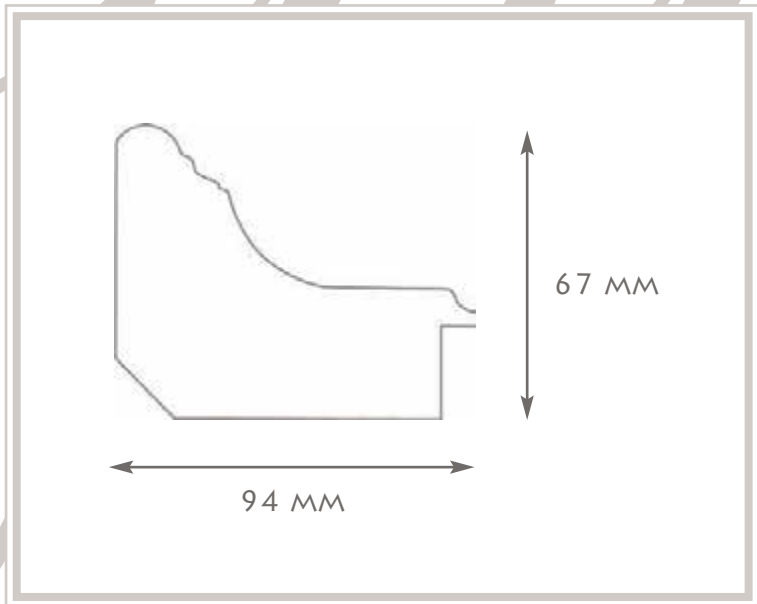

2.

ART. DEGAS

FINITURA ARTIGIANALE / HANDCRAFT FINISH



Art



De

FINITURE DISPONIBILI / AVAILABLE FINISH:

1. ART. DEGAS ORO - NERO / GOLD - BLACK DEGAS
2. ART. DEGAS ORO RESTAURO / OLD GOLD DEGAS



1.

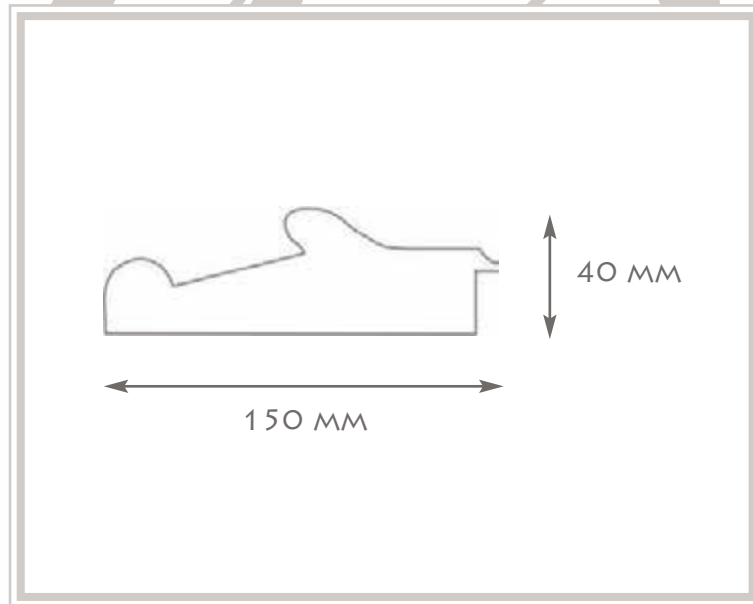

2.



ART. KLIMT

FINITURA ARTIGIANALE / HANDCRAFT FINISH



mt



Klimt

FINITURE DISPONIBILI / AVAILABLE FINISH:

1. ART. KLIMT ORO CHIARO / LIGHT GOLD KLIMT
2. ART. KLIMT ORO BRUNO / GOLD BRUNISHED KLIMT



1.

mt

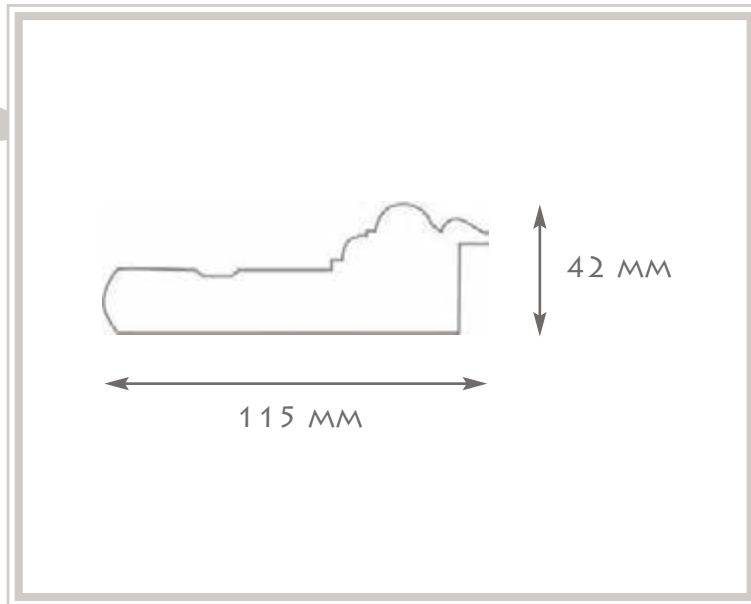

2.

ART. LEONARDO

FINITURA ARTIGIANALE / HANDCRAFT FINISH



notrdo



Leonardo

FINITURE DISPONIBILI / AVAILABLE FINISH:

1. ART. LEONARDO AVORIO / IVORY LEONARDO
2. ART. LEONARDO ORO - NERO / GOLD - BLACK LEONARDO



1.

catredo

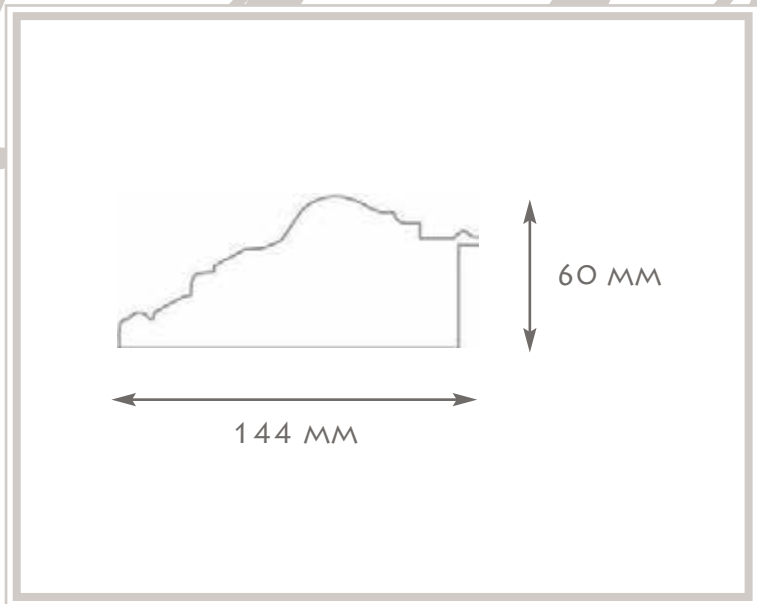

2.

ART. LIBERTY

FINITURA ARTIGIANALE

/ HANDCRAFT FINISH

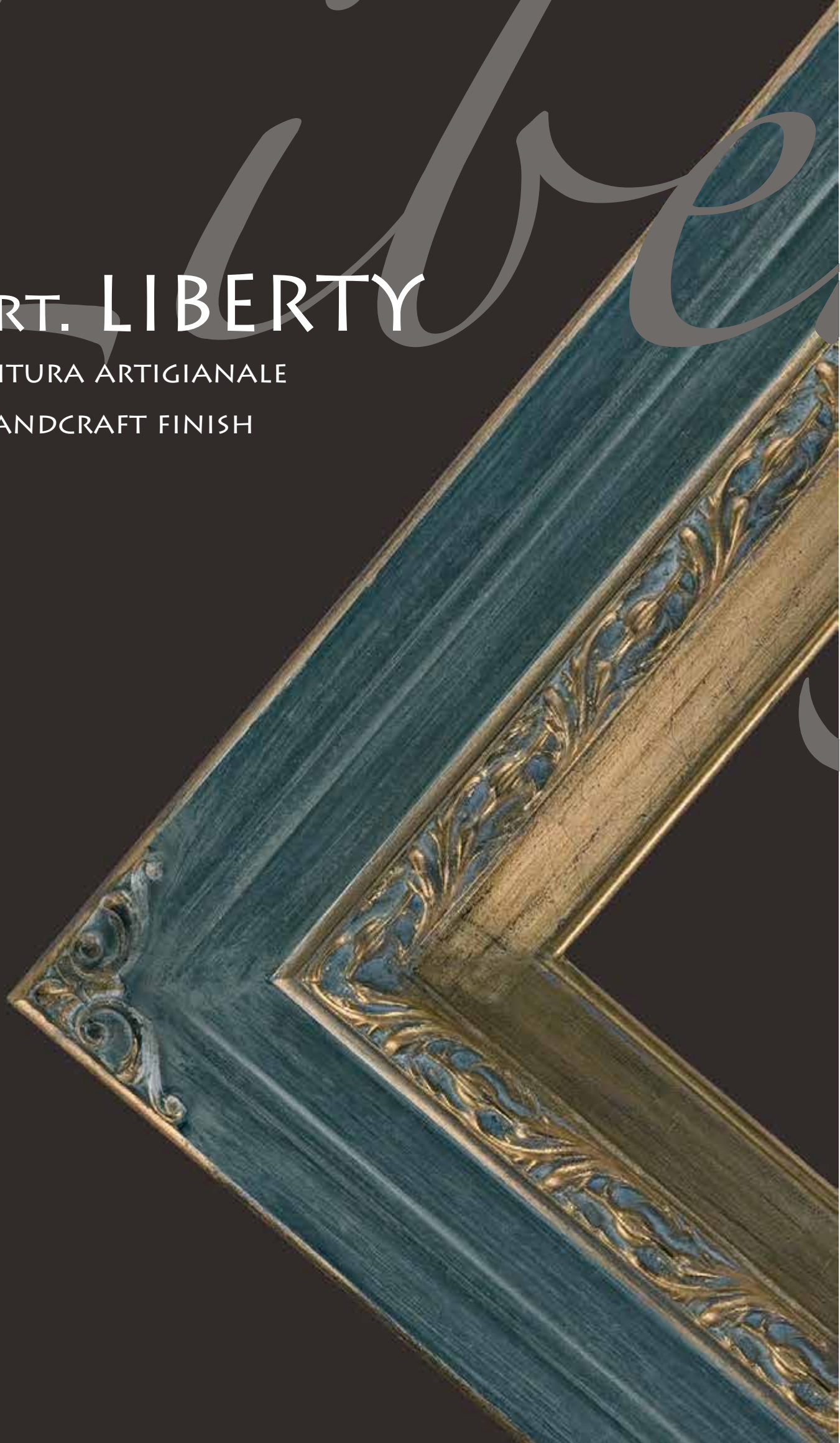

Art



Liberty

FINITURE DISPONIBILI / AVAILABLE FINISH:

1. ART. LIBERTY VERDE / GREEN LIBERTY
2. ART. LIBERTY ORO / GOLD LIBERTY
3. ART. LIBERTY BLU / BLUE LIBERTY

1.



2.



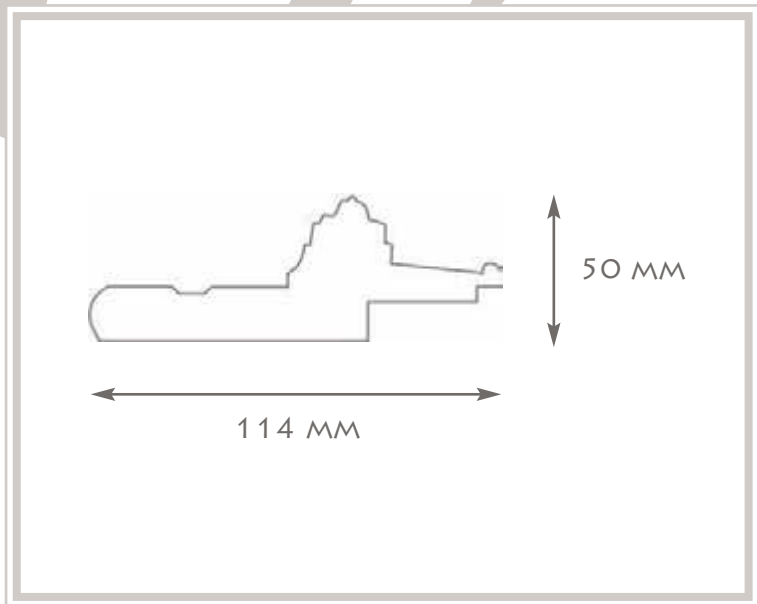

3.



ART. LOTTO

FINITURA ARTIGIANALE / HANDCRAFT FINISH

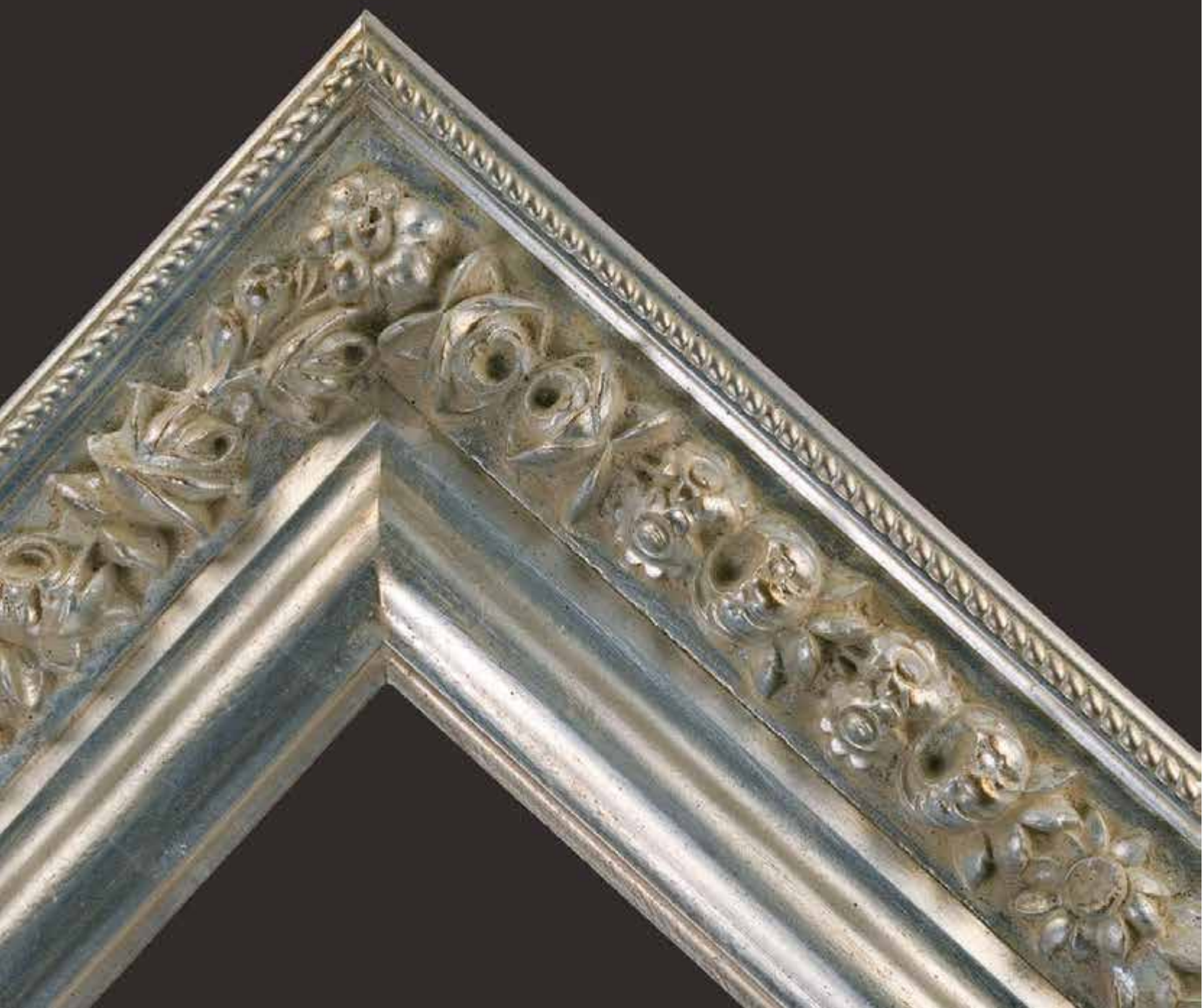

La



PAG.47



Lotto

FINITURE DISPONIBILI / AVAILABLE FINISH:

1. ART. LOTTO ORO / GOLD LOTTO
2. ART. LOTTO ARGENTO / SILVER LOTTO

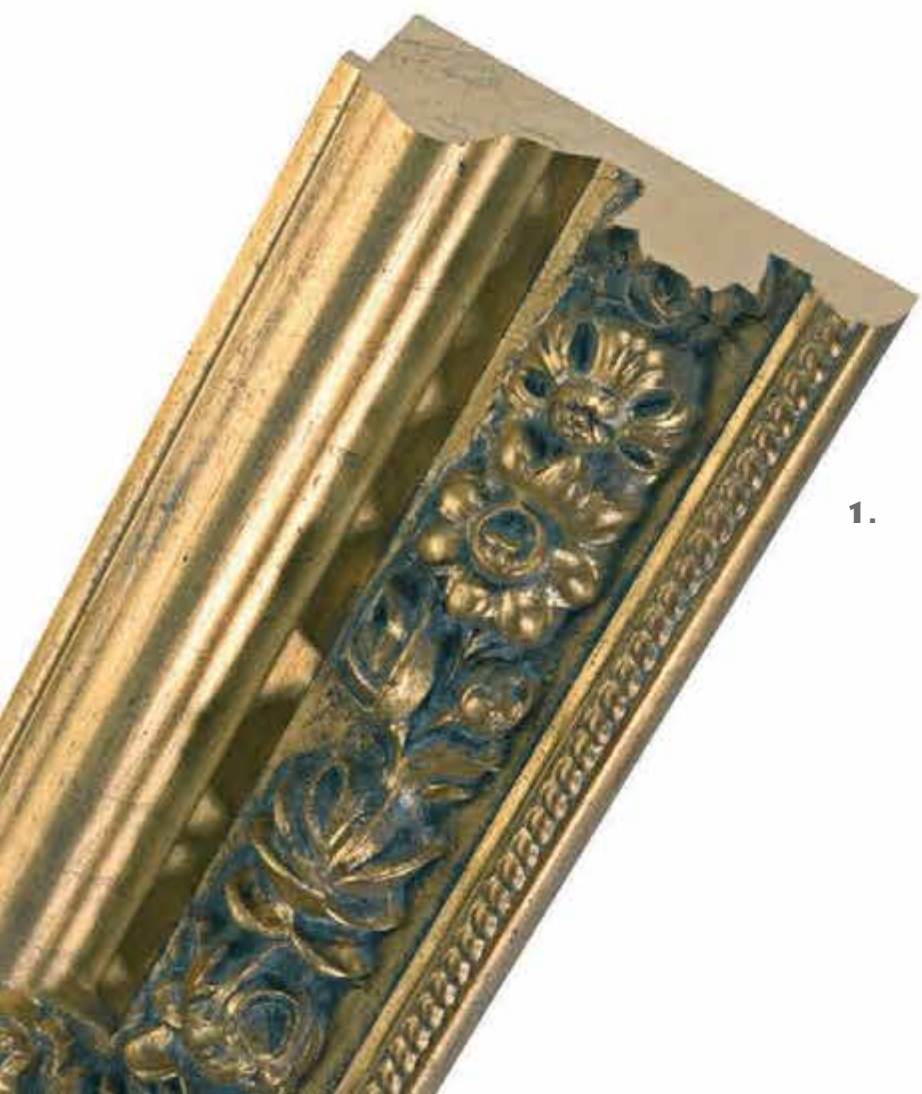

1.

da

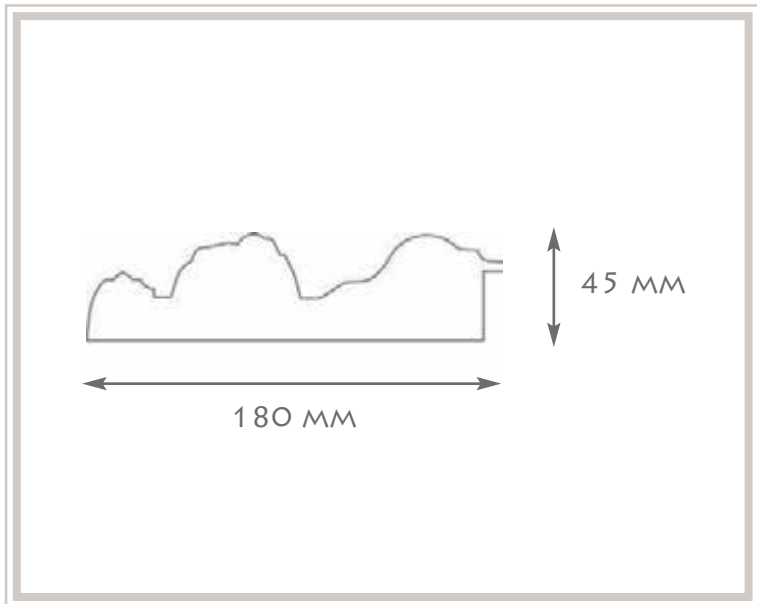

2.

Love
ART. LOVERINI

FINITURA ARTIGIANALE / HANDCRAFT FINISH

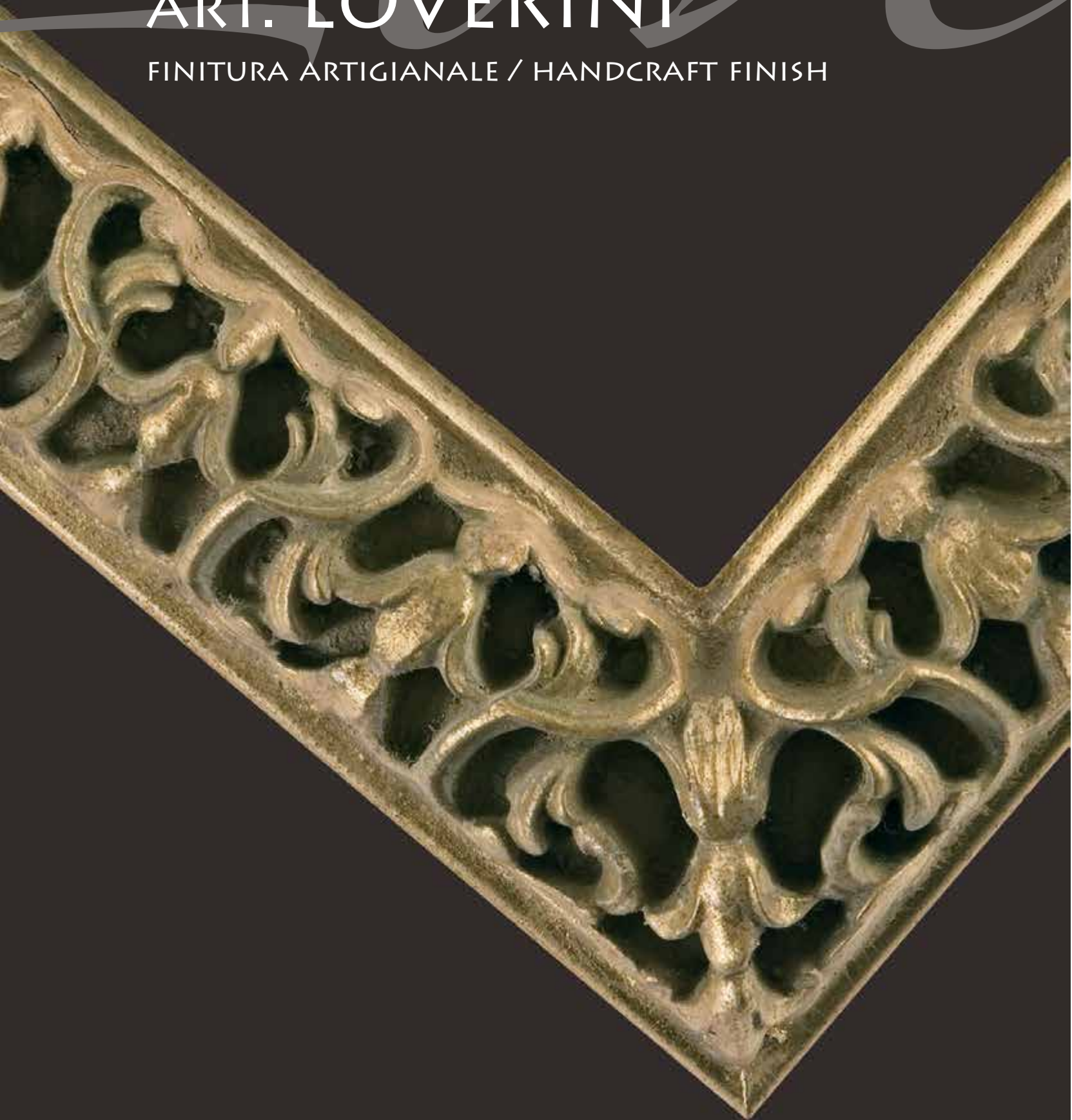

Ormai



PAG.51



Loyve

FINITURE DISPONIBILI / AVAILABLE FINISH:

1. ART. LOVERINI ORO / GOLD LOVERINI
2. ART. LOVERINI ARGENTO / SILVER LOVERINI



1.

primo

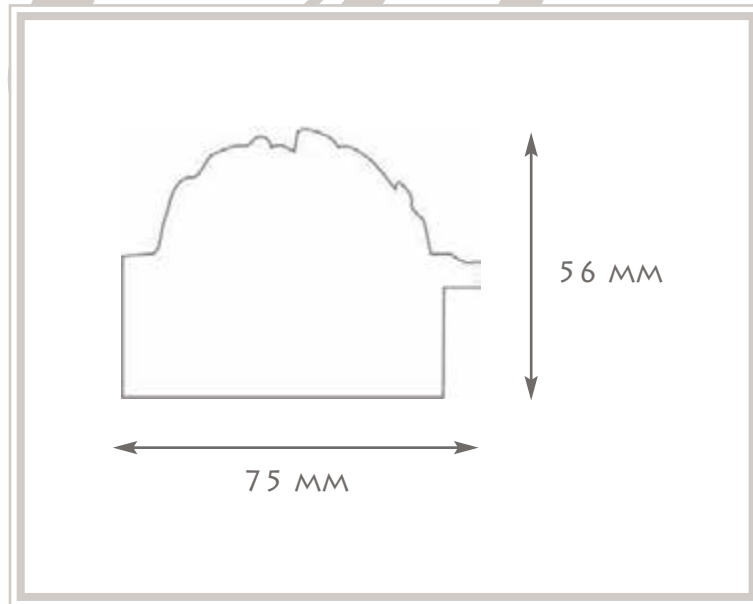



ART. MONET

FINITURA ARTIGIANALE

/ HANDCRAFT FINISH

report



PAG.55



May

FINITURE DISPONIBILI / AVAILABLE FINISH:

1. ART. MONET ORO - GOLA AVORIO / GOLD - IVORY CYMA MONET
2. ART. MONET GOLA BLU / BLUE CYMA MONET



1.

report

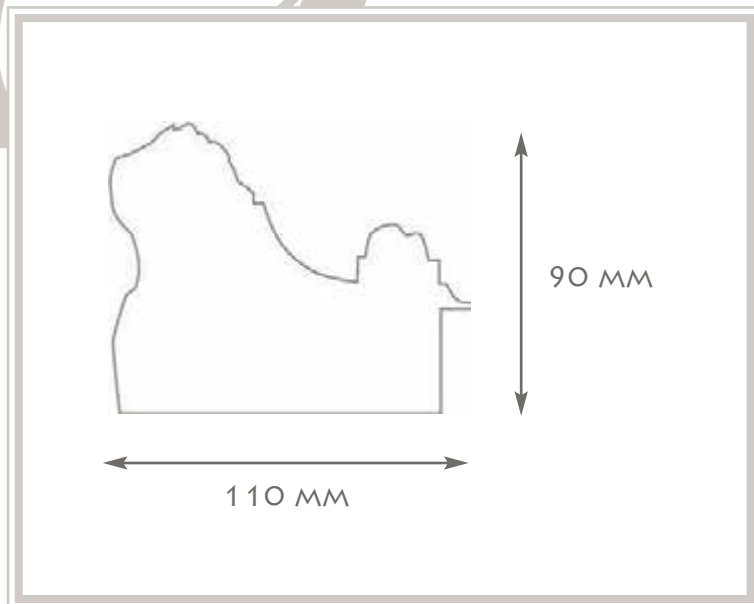

PAG.57

2.



A close-up photograph of a handcrafted metal corner, likely a decorative element for a window or door. The metal is heavily textured and features intricate, hand-carved scrollwork and floral patterns. The surface is finished with a gold leaf, which is unevenly applied, highlighting the texture and the depth of the carvings. The background is dark, making the metallic details stand out.

ART. PICCIO

FINITURA ARTIGIANALE / HANDCRAFT FINISH

Ux



Piccio

FINITURE DISPONIBILI / AVAILABLE FINISH:

1. ART. PICCIO AVORIO / IVORY PICCIO
2. ART. PICCIO NERO / BLACK PICCIO

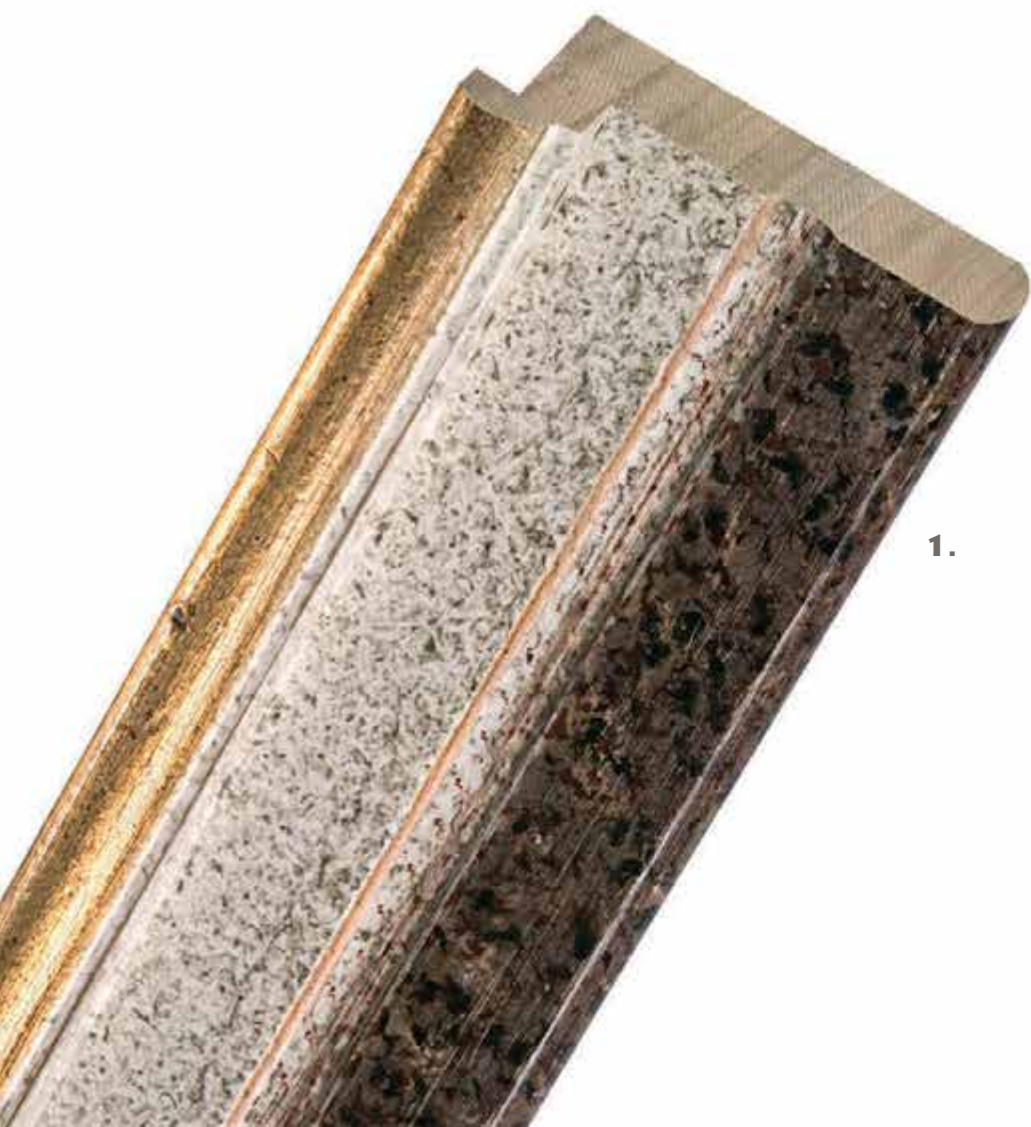

1.

COX

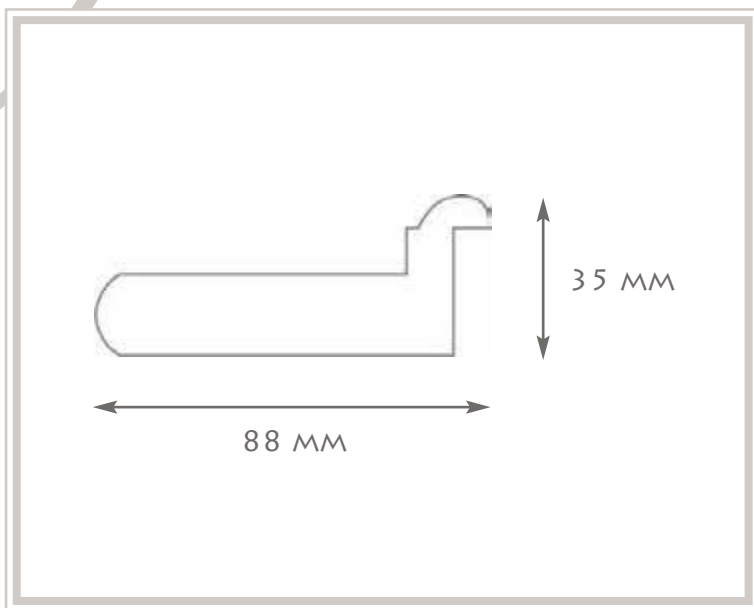

PAG.61

2.



ART. RENOIR

FINITURA ARTIGIANALE / HANDCRAFT FINISH



Or



PAG.63



Renoir

FINITURE DISPONIBILI / AVAILABLE FINISH:

1. ART. RENOIR ORO / GOLD RENOIR
2. ART. RENOIR ARGENTO / SILVER RENOIR



1.

Or

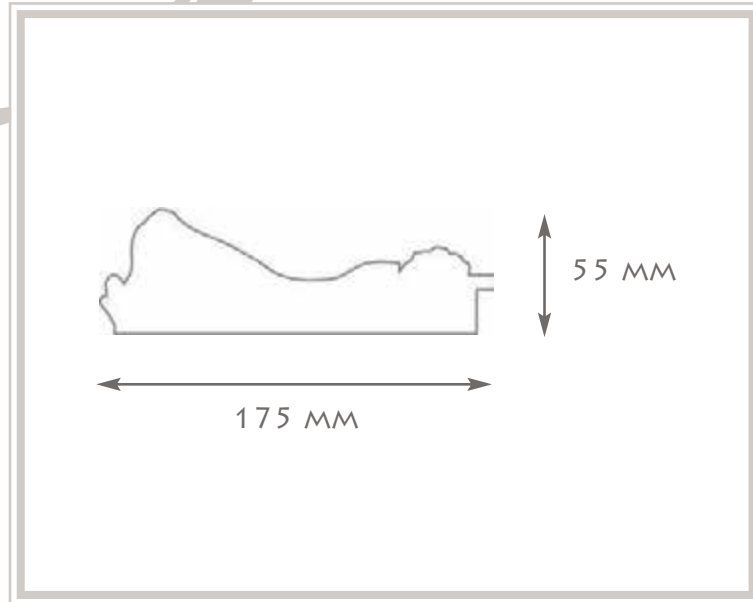

ART. RUBENS

FINITURA ARTIGIANALE / HANDCRAFT FINISH

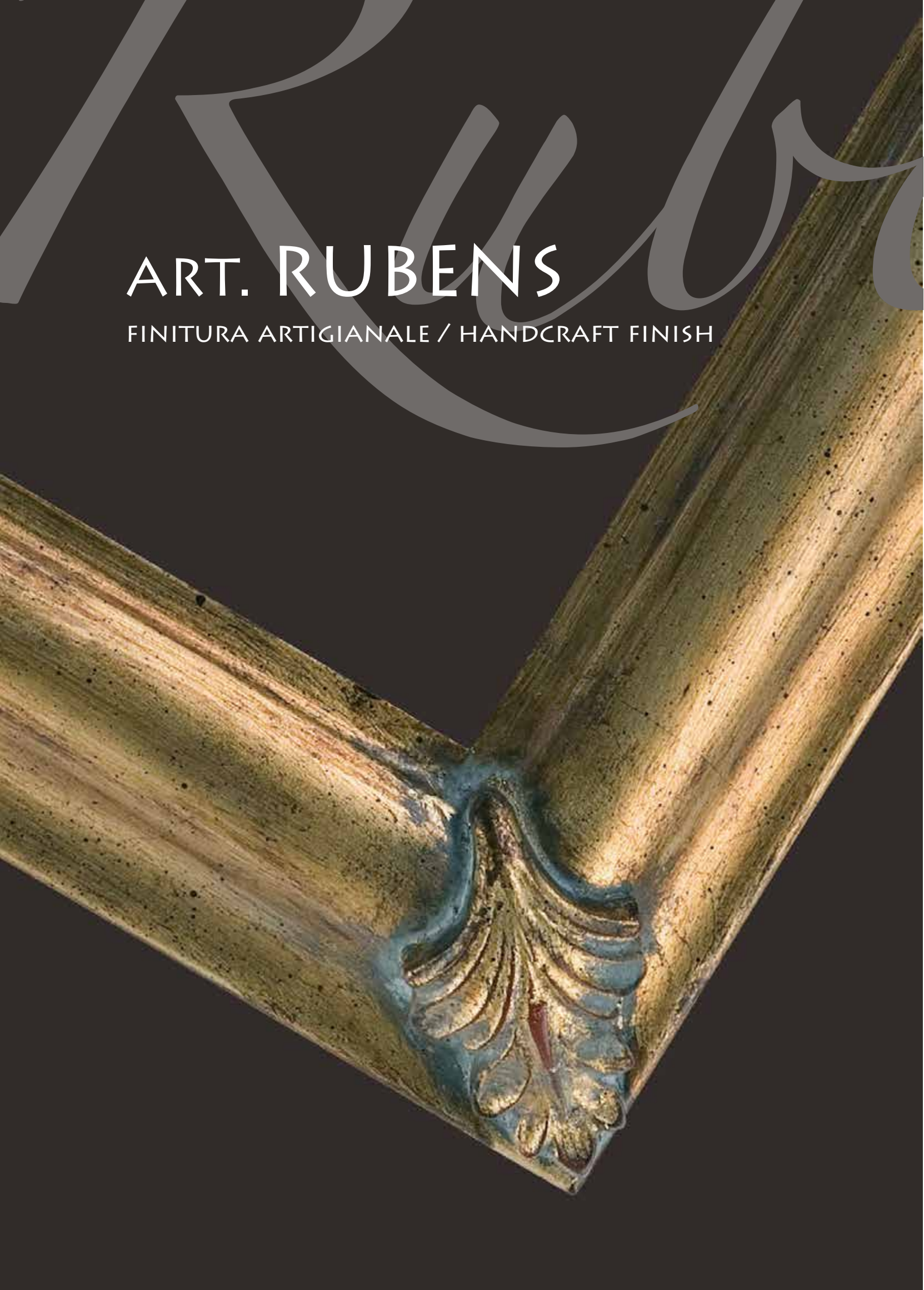

ems



PAG.67



Rubens

FINITURE DISPONIBILI / AVAILABLE FINISH:

1. ART. RUBENS ARGENTO / SILVER RUBENS
2. ART. RUBENS ORO / GOLD RUBENS
3. ART. RUBENS NERO+SF / BLACK+SF RUBENS

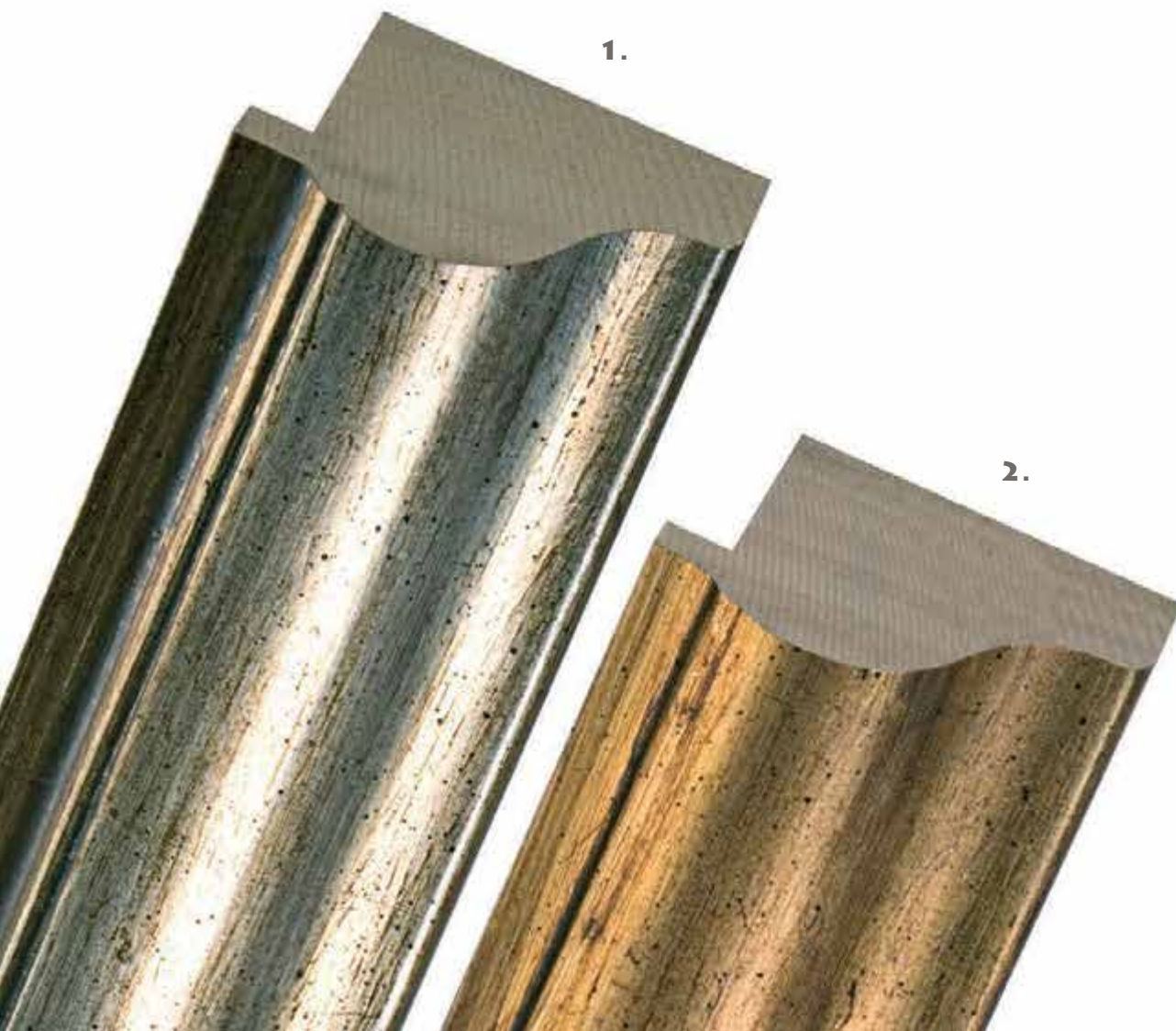

ENR

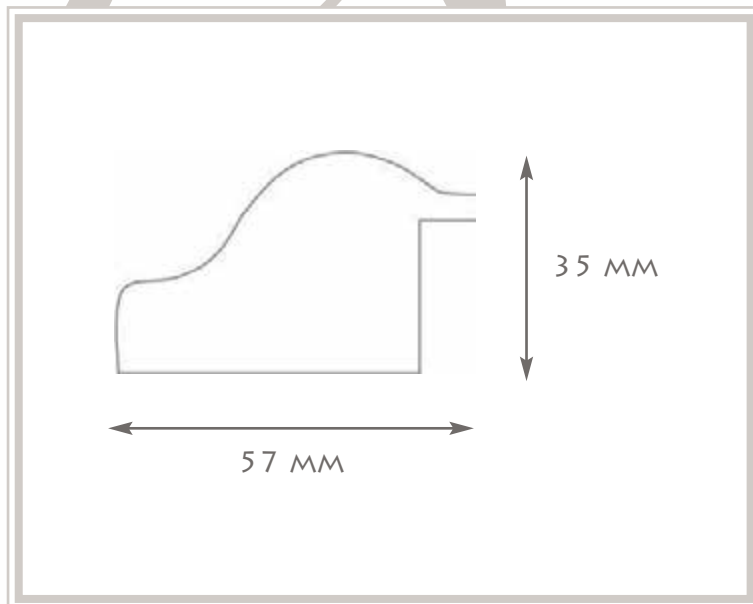

PAG.69

3.

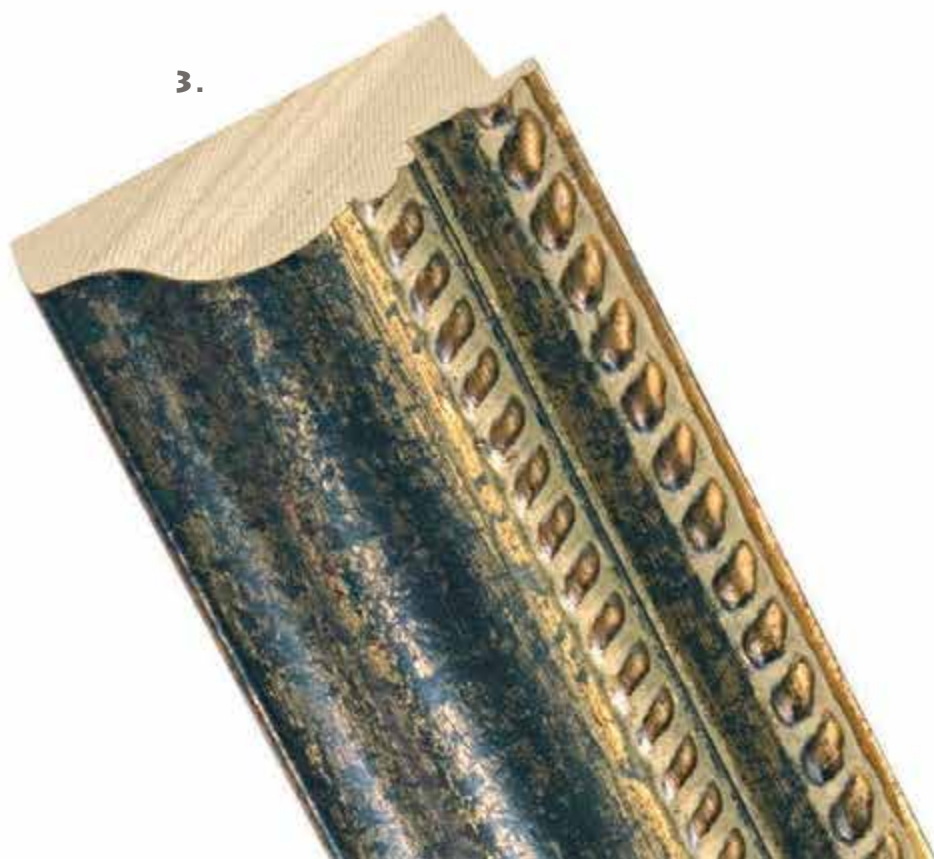

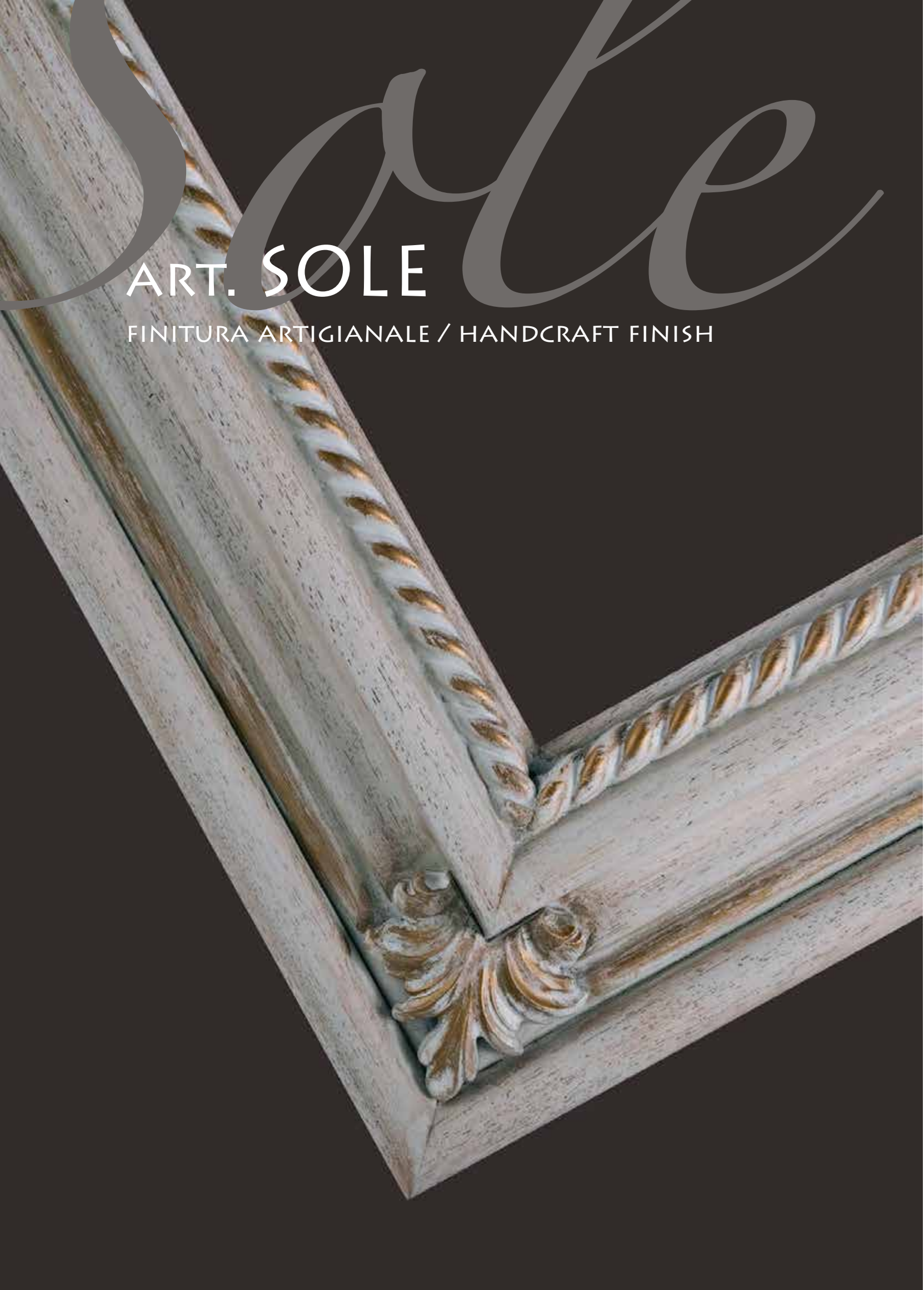

SALE

ART. SOLE

FINITURA ARTIGIANALE / HANDCRAFT FINISH



Sole

FINITURE DISPONIBILI / AVAILABLE FINISH:

1. ART. SOLE AVORIO / IVORY SOLE
2. ART. SOLE BLU / BLUE SOLE
3. ART. SOLE ORO / GOLD SOLE

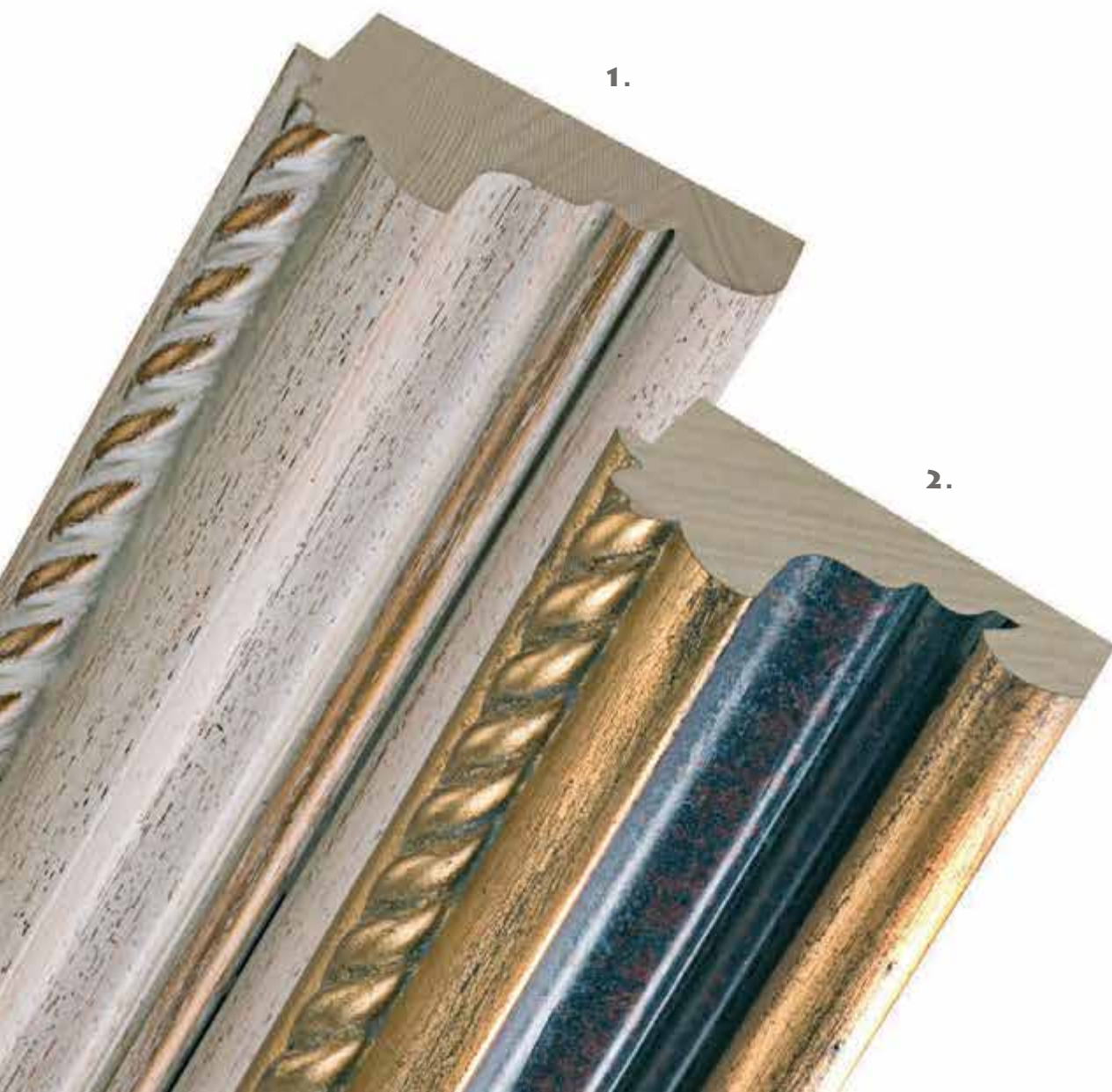

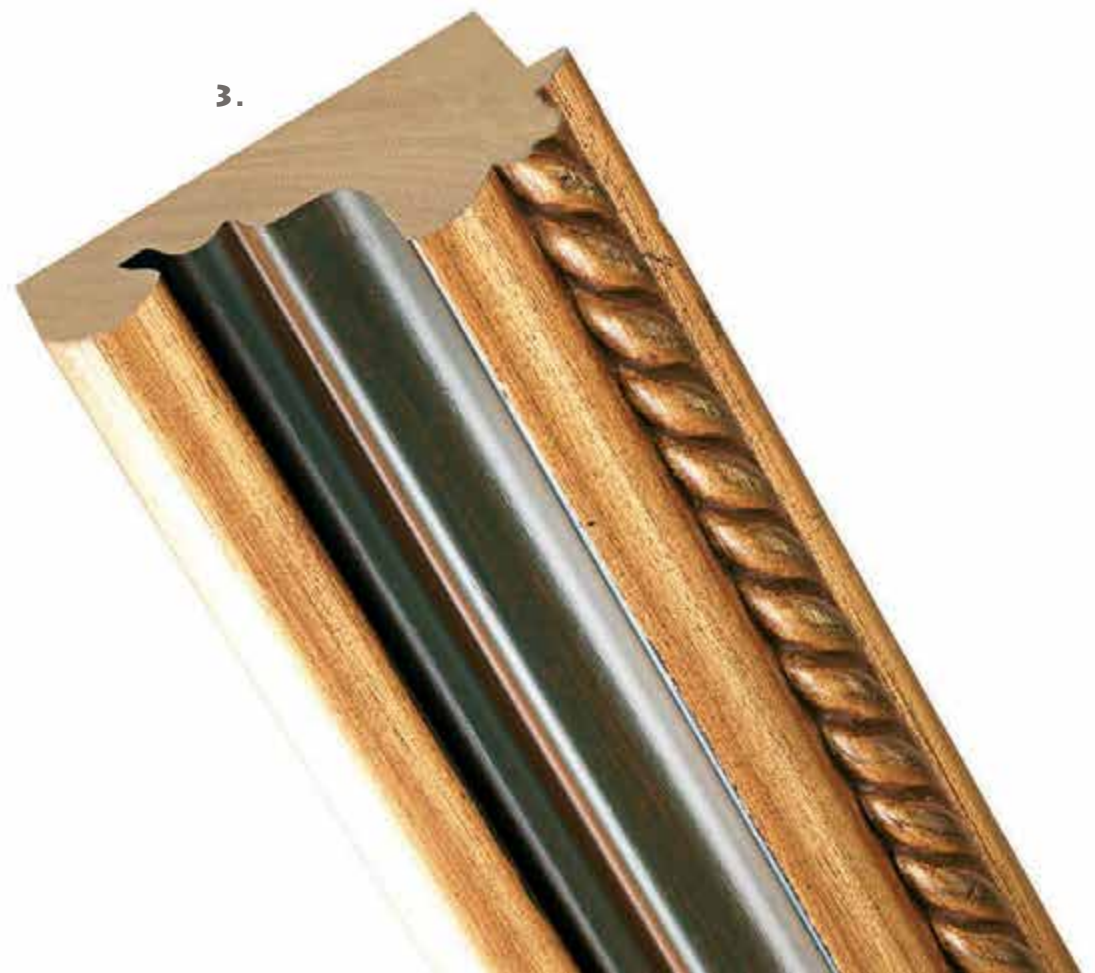
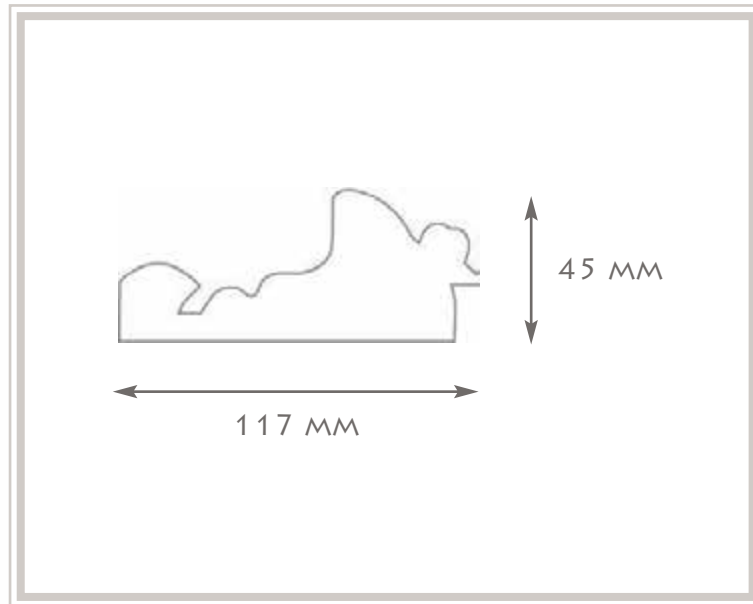

ART. TINTORETTO

FINITURA ARTIGIANALE / HANDCRAFT FINISH



reportage



PAG.75



Tintoretto

FINITURE DISPONIBILI / AVAILABLE FINISH:

1. ART. TINTORETTO ORO - NERO / GOLD - BLACK TINTORETTO
2. ART. TINTORETTO ARGENTO - ROCK / SILVER - ROCK TINTORETTO



1.

report

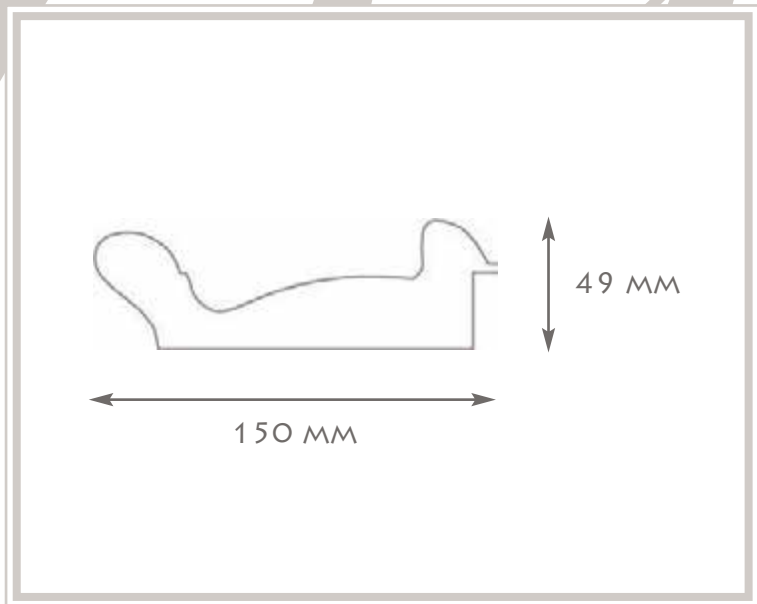

2.

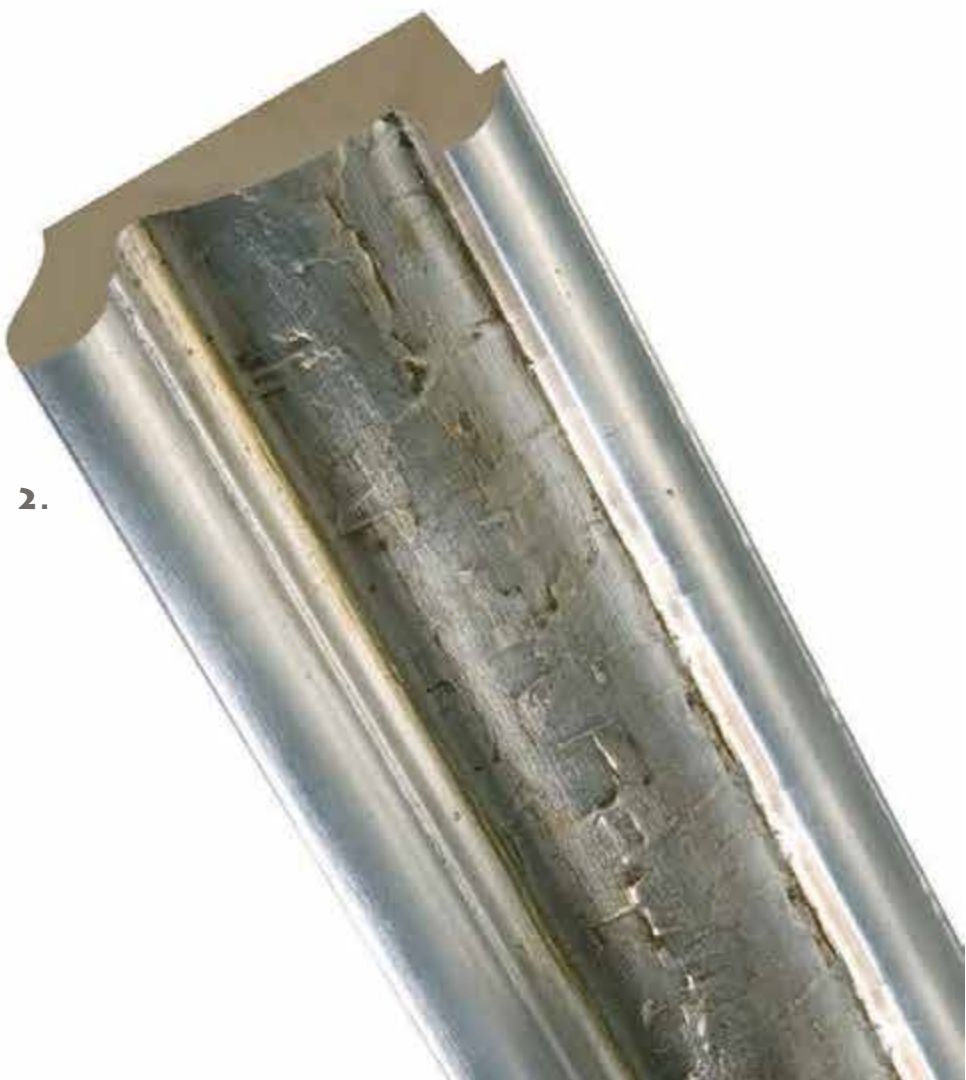

ART. TIZIANO

FINITURA ARTIGIANALE / HANDCRAFT FINISH



Storia



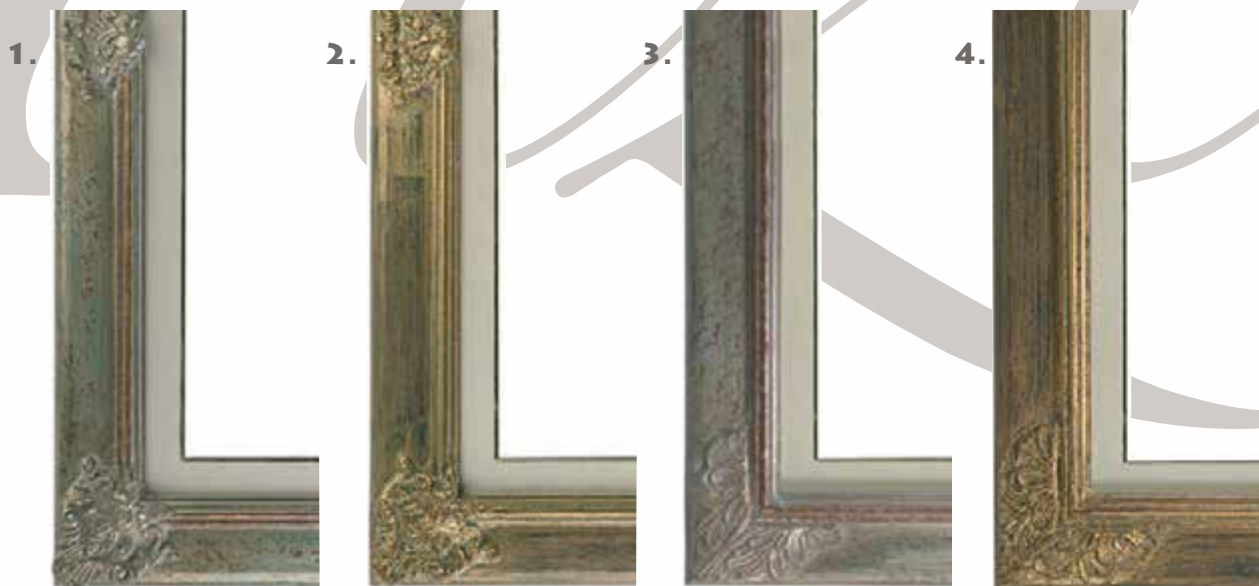

FINITURE DISPONIBILI TIZIANO - 8 FREG I / AVAILABLE FINISH - 8 FRIEZES TIZIANO:

1. ART. TIZIANO ARGENTO B8 / SILVER B8 TIZIANO

2. ART. TIZIANO ORO B8 / GOLD B8 TIZIANO



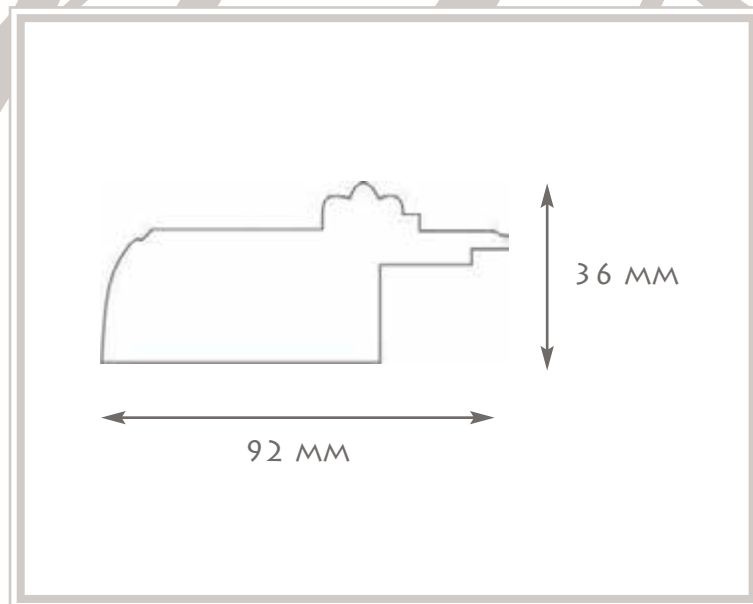

FINITURE DISPONIBILI - TIZIANO 4 FREGI / AVAILABLE FINISH - 4 FRIEZES TIZIANO:

3. ART. TIZIANO ARGENTO B4 / SILVER B4 TIZIANO

4. ART. TIZIANO ORO B4 / GOLD B4 TIZIANO

PAG.81



ART. VAN GOGH

FINITURA ARTIGIANALE

/ HANDCRAFT FINISH

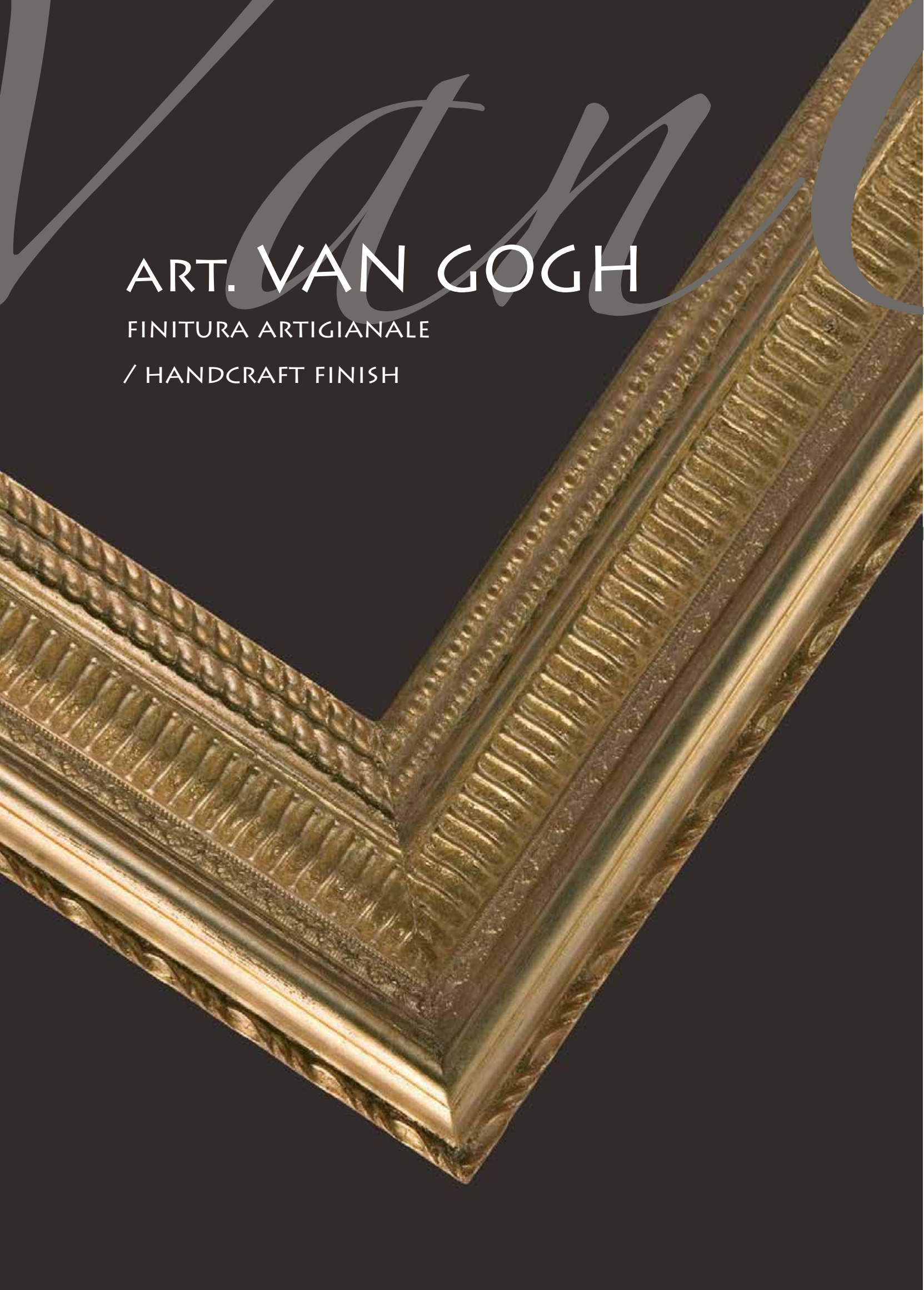



Vatno

FINITURE DISPONIBILI / AVAILABLE FINISH:

1. ART. VAN GOGH ORO / GOLD VAN GOGH
2. ART. VAN GOGH ARGENTO / SILVER VAN GOGH

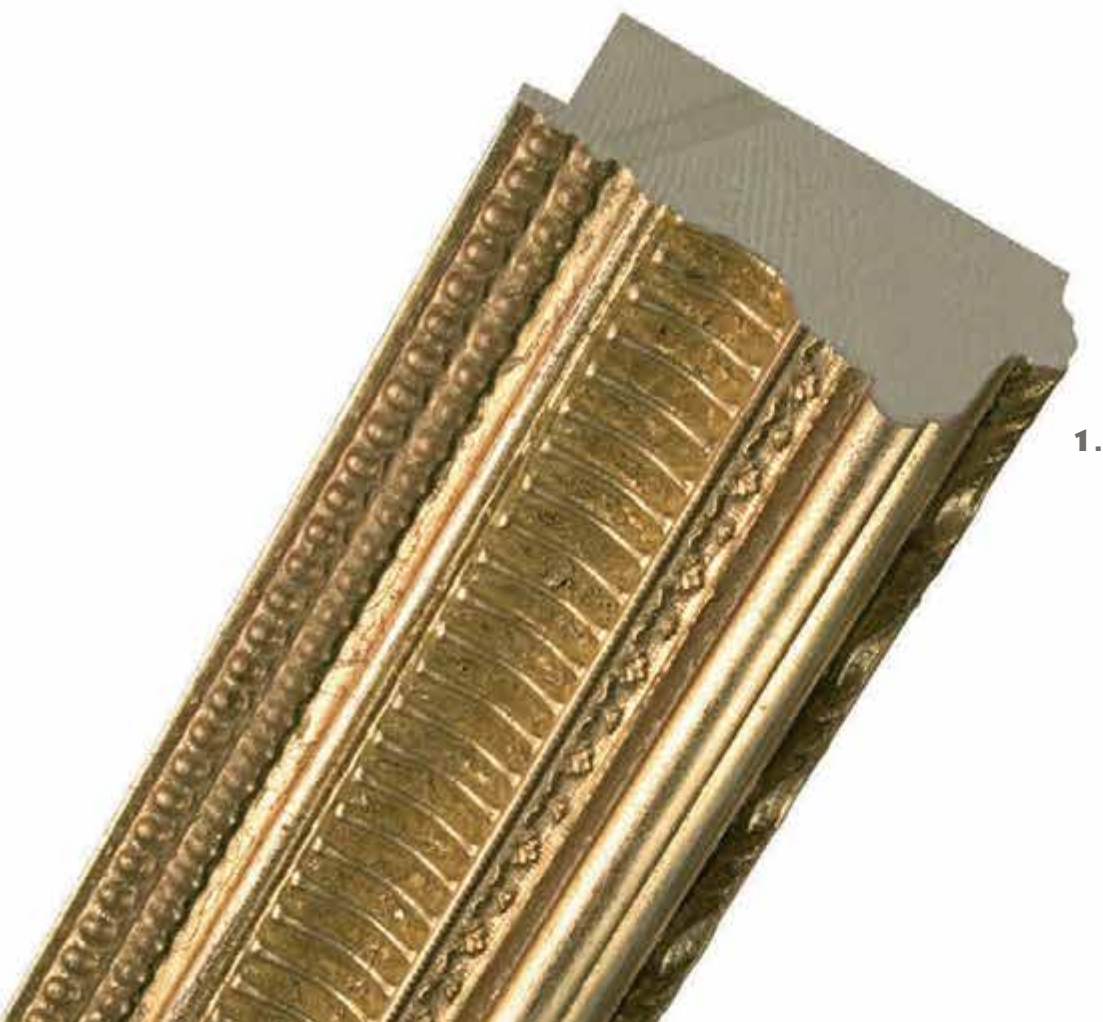

1.

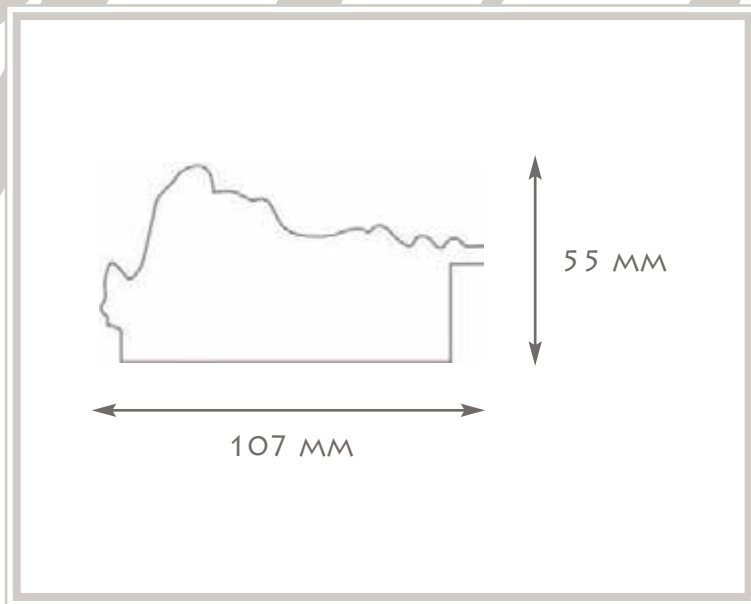

2.

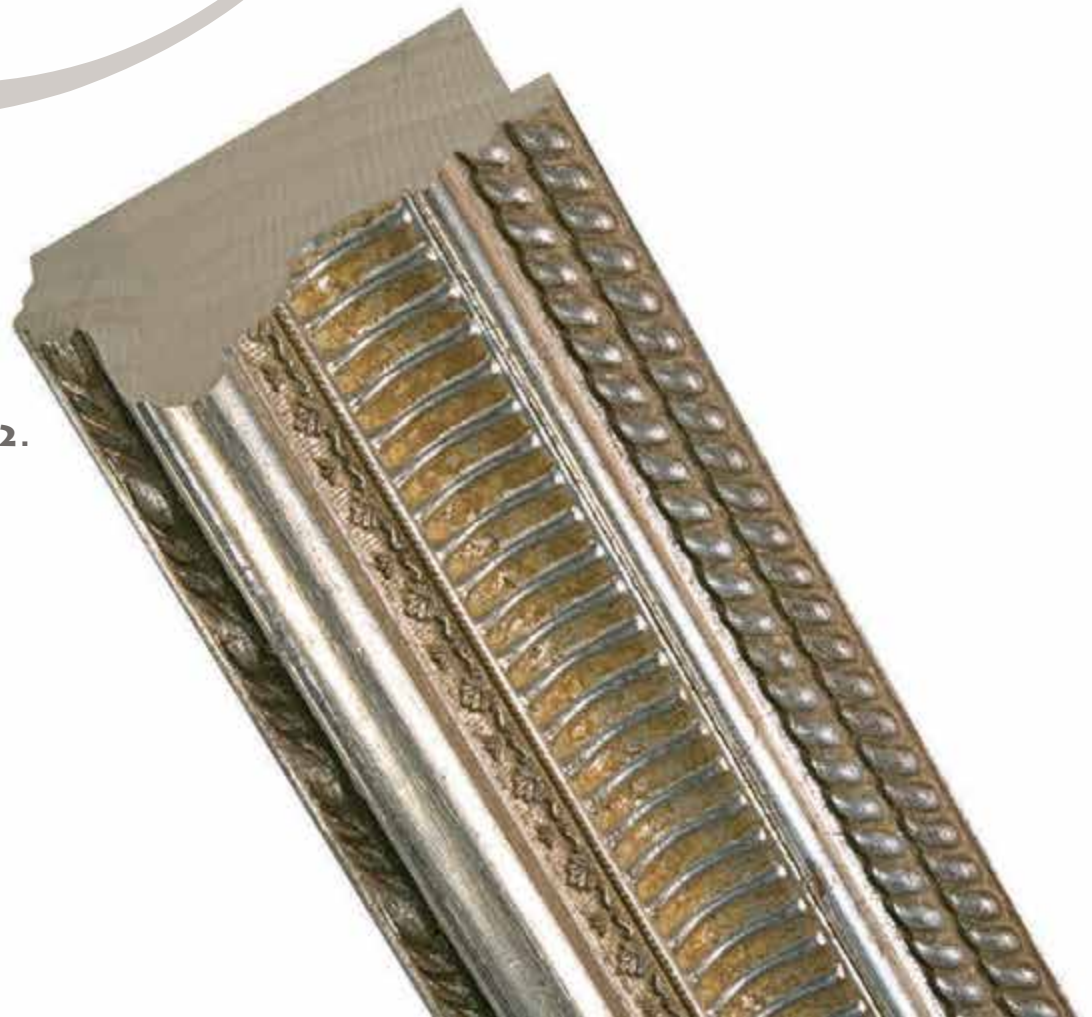

Velasquez
ART. VELASQUEZ

FINITURA ARTIGIANALE / HANDCRAFT FINISH

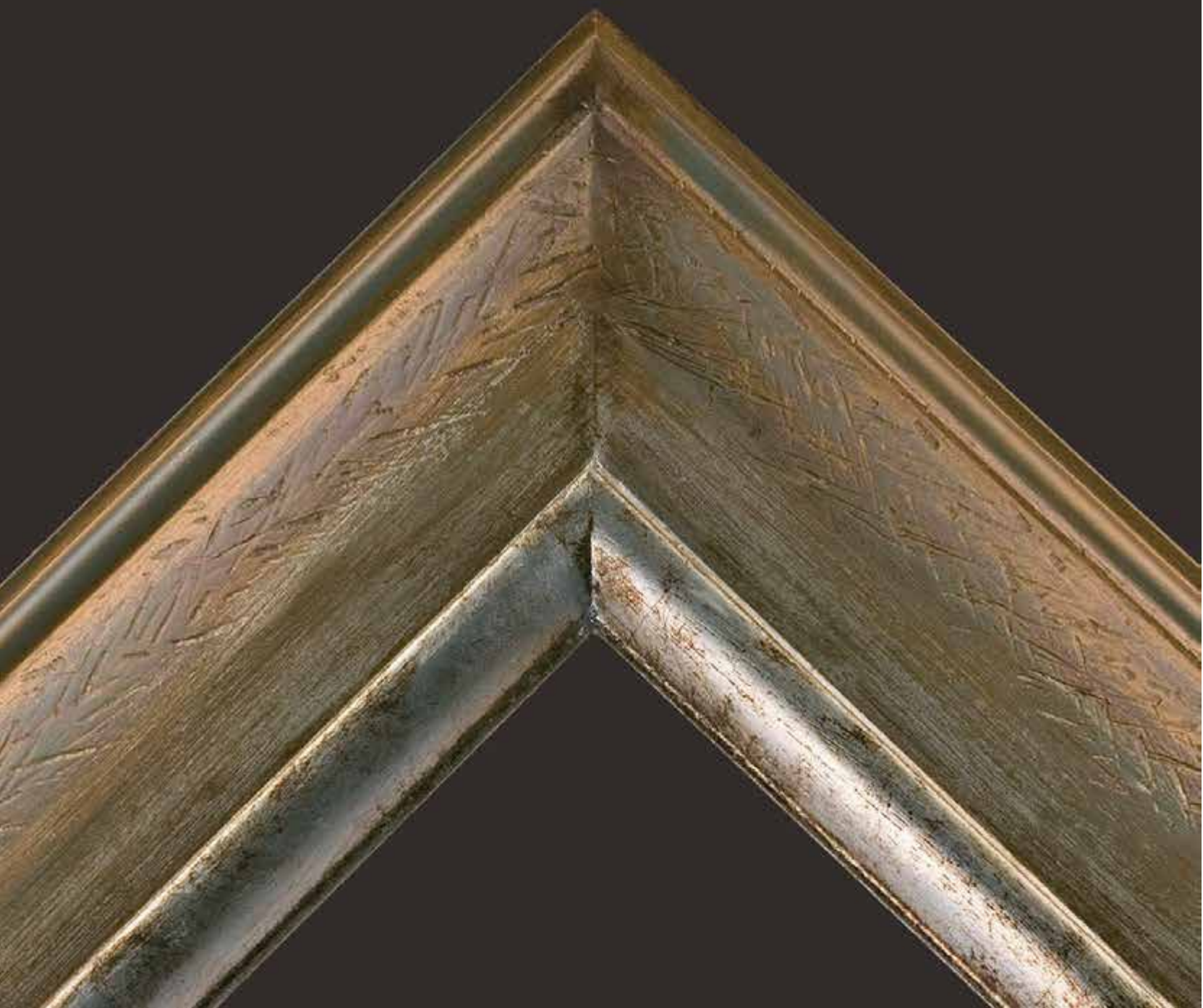

ts
s
u
e



PAG.87



Velvet

FINITURE DISPONIBILI / AVAILABLE FINISH:

1. ART. VELASQUEZ ARGENTO GRAFFIATO / SILVERSCRATCH VELASQUEZ
2. ART. VELASQUEZ ORO (FINITURA TIPO RENOIR) / GOLD VELASQUEZ (SIMILAR FINISHRENOIR)



1.

stature

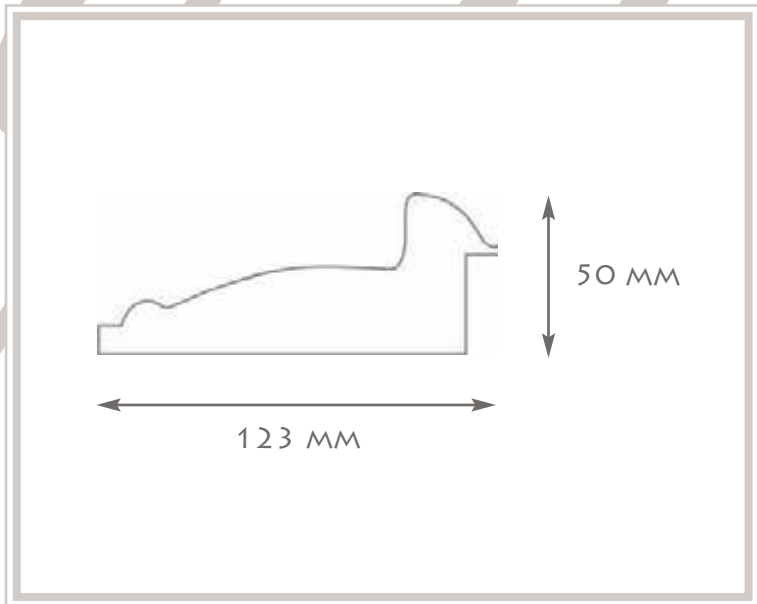

2.



ART. ZOR

FINITURA ARTIGIANALE / HANDCRAFT FINISH



Zor

FINITURE DISPONIBILI / AVAILABLE FINISH:

1. ART. ZOR BLU / BLUE ZOR

2. ART. ZOR ROSSO / RED ZOR

3. ART. ZOR VERDE / GREEN ZOR

4. ART. ZOR ROCK ZOR

5. ART. ZOR ORO - AVORIO / GOLD - IVORY ZOR

6. ART. ZOR ARGENTO - AVORIO / SILVER - IVORY ZOR



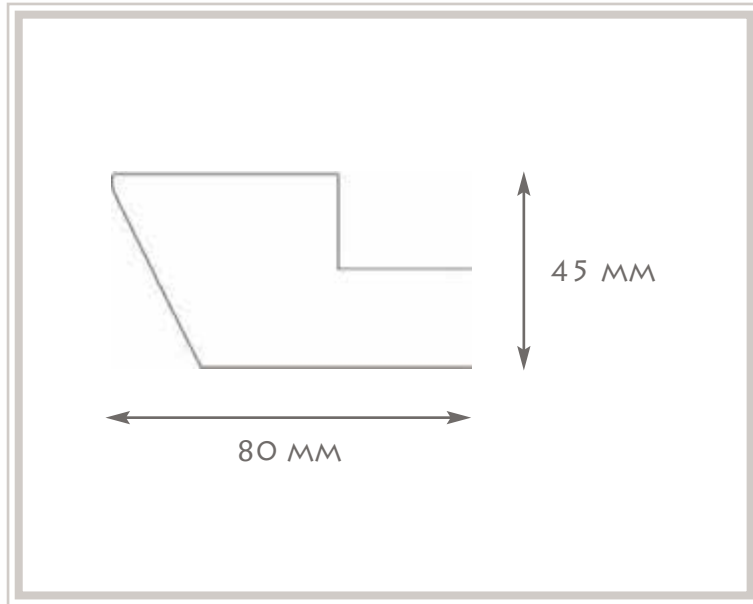

ART. ORO ZECCHINO
ART. ARGENTO VERO

FINITURA ARTIGIANALE

/ HANDCRAFT FINISH



Arde



ART. ORO ZECCHINO /PURE GOLD

FINITURE DISPONIBILI / AVAILABLE FINISH:

1. ART. ORO ZECCHINO D95
/ PURE GOLD D95
2. ART. ORO ZECCHINO P66
/ PURE GOLD P66
3. ART. ORO ZECCHINO 2005
/ PURE GOLD 2005
4. ART. ORO ZECCHINO AP84
/ PURE GOLD AP84
5. ART. ORO ZECCHINO A27
/ PURE GOLD A27

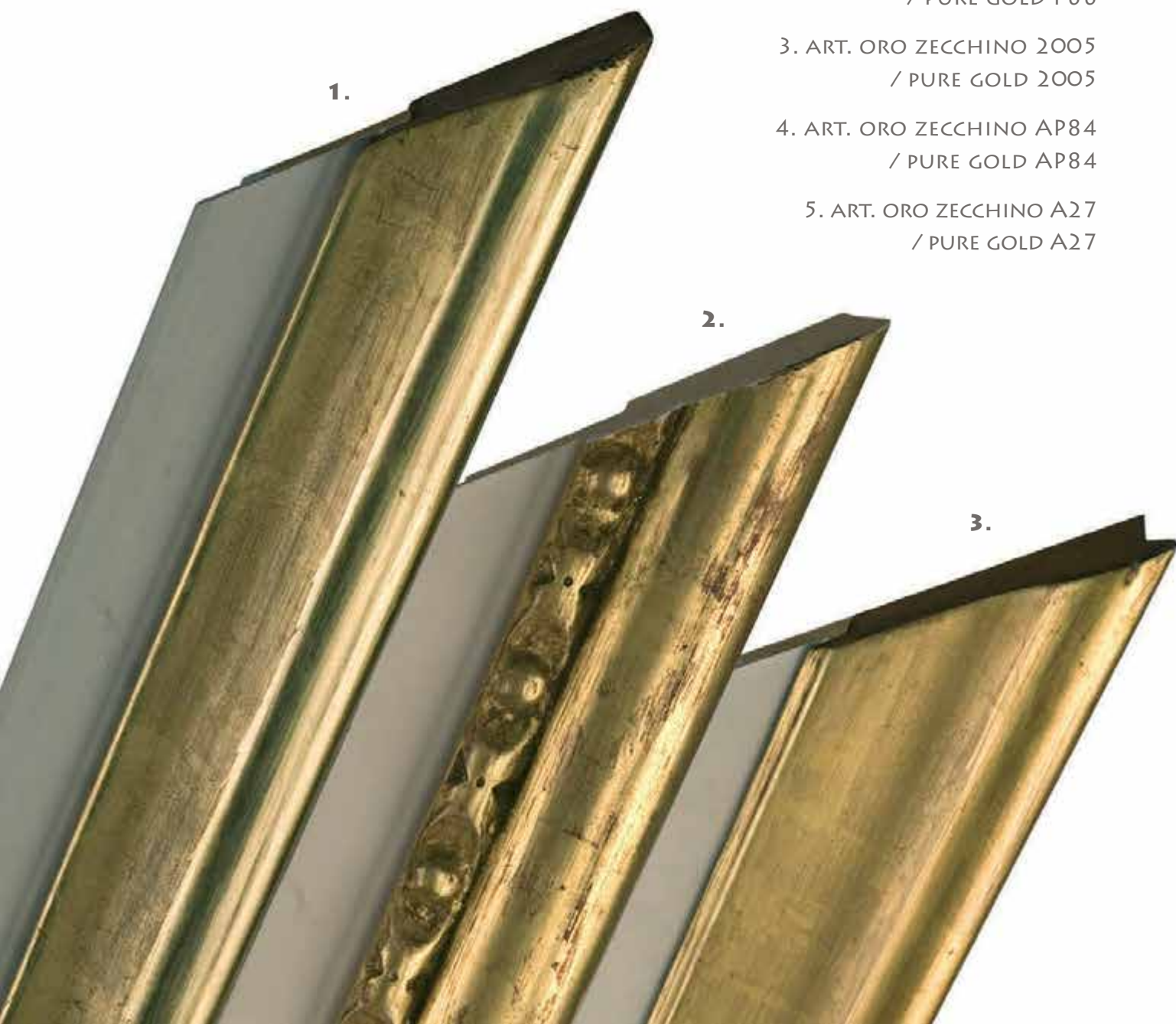

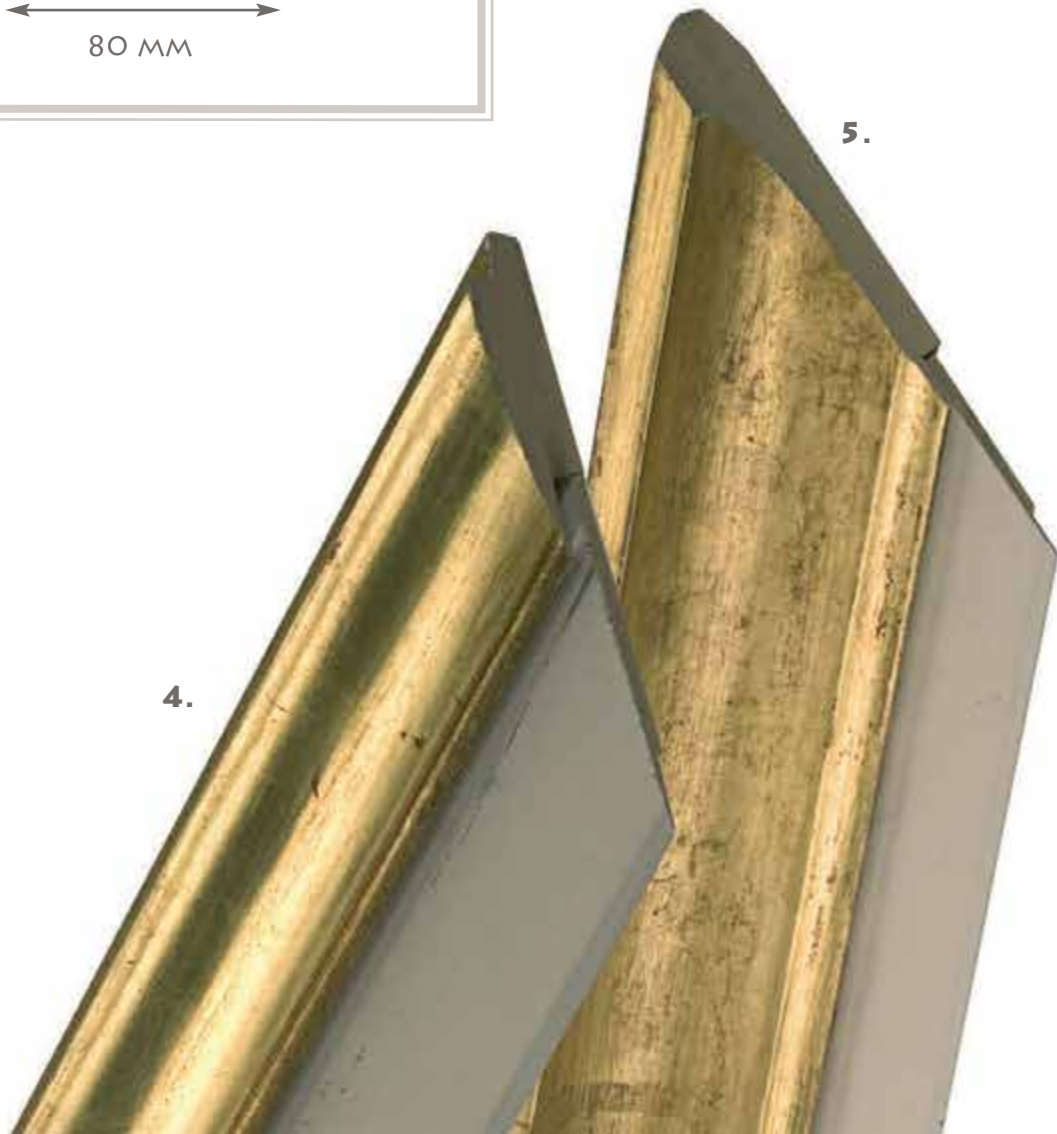
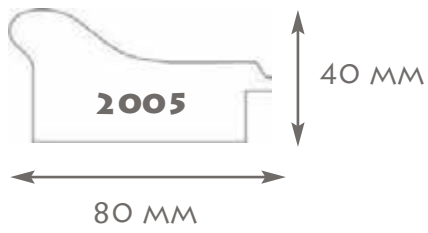
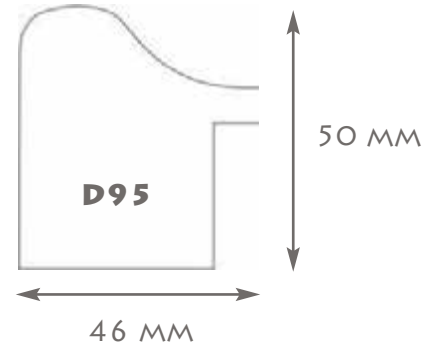
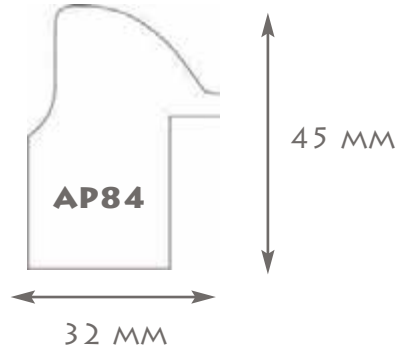
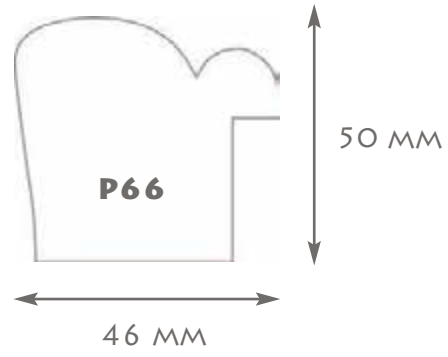
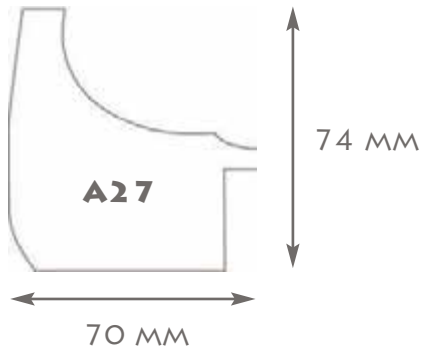

ART. ARGENTO VERO /PURE SILVER

FINITURE DISPONIBILI / AVAILABLE FINISH:

1. ART. ARGENTO VERO D95
/ PURE SILVER D95

2. ART. ARGENTO VERO P66
/ PURE SILVER P66

3. ART. ARGENTO VERO 2005
/ PURE SILVER 2005

4. ART. ARGENTO VERO AP84
/ PURE SILVER AP84

5. ART. ARGENTO VERO A27
/ PURE SILVER A27

1.

2.

3.

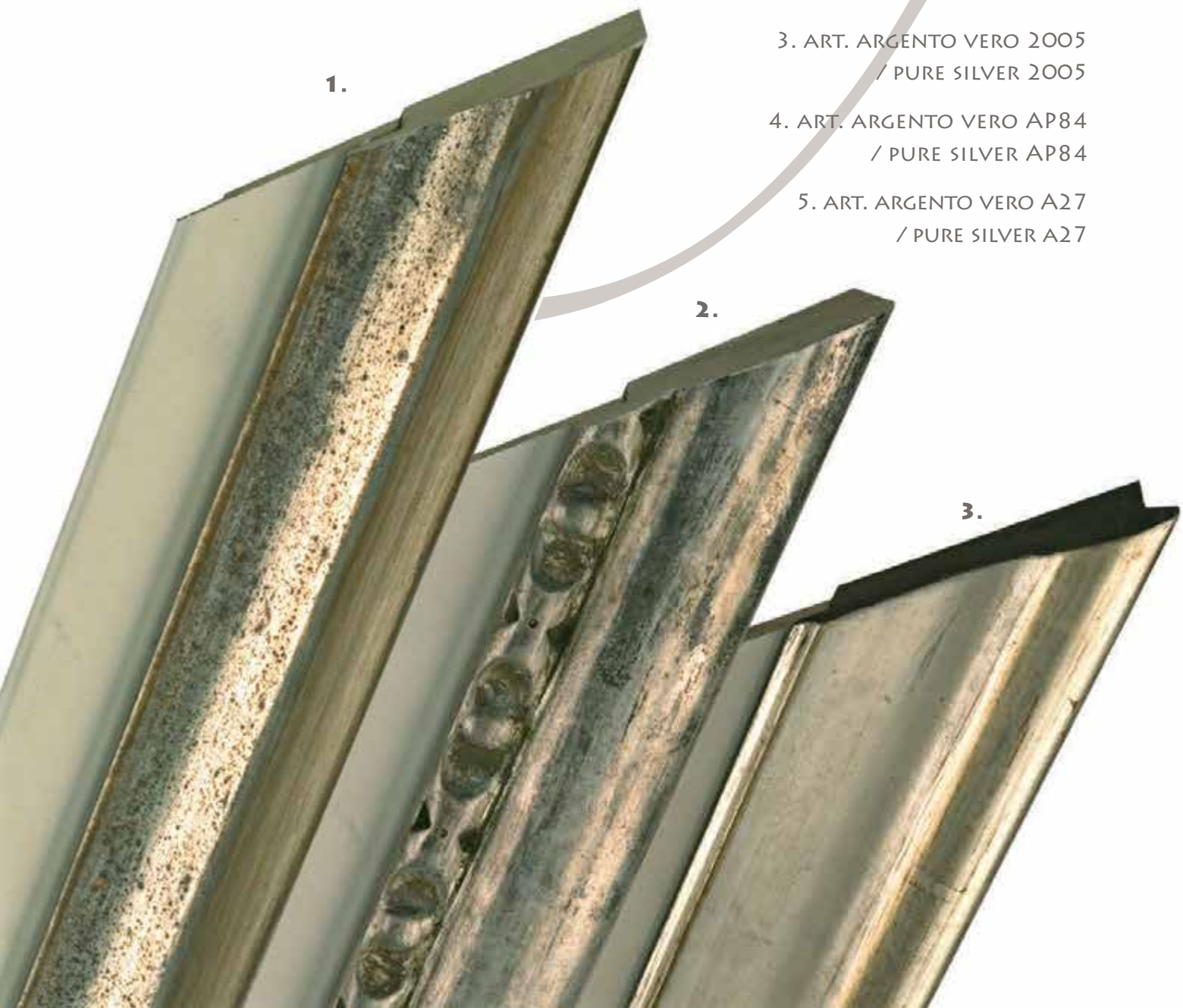

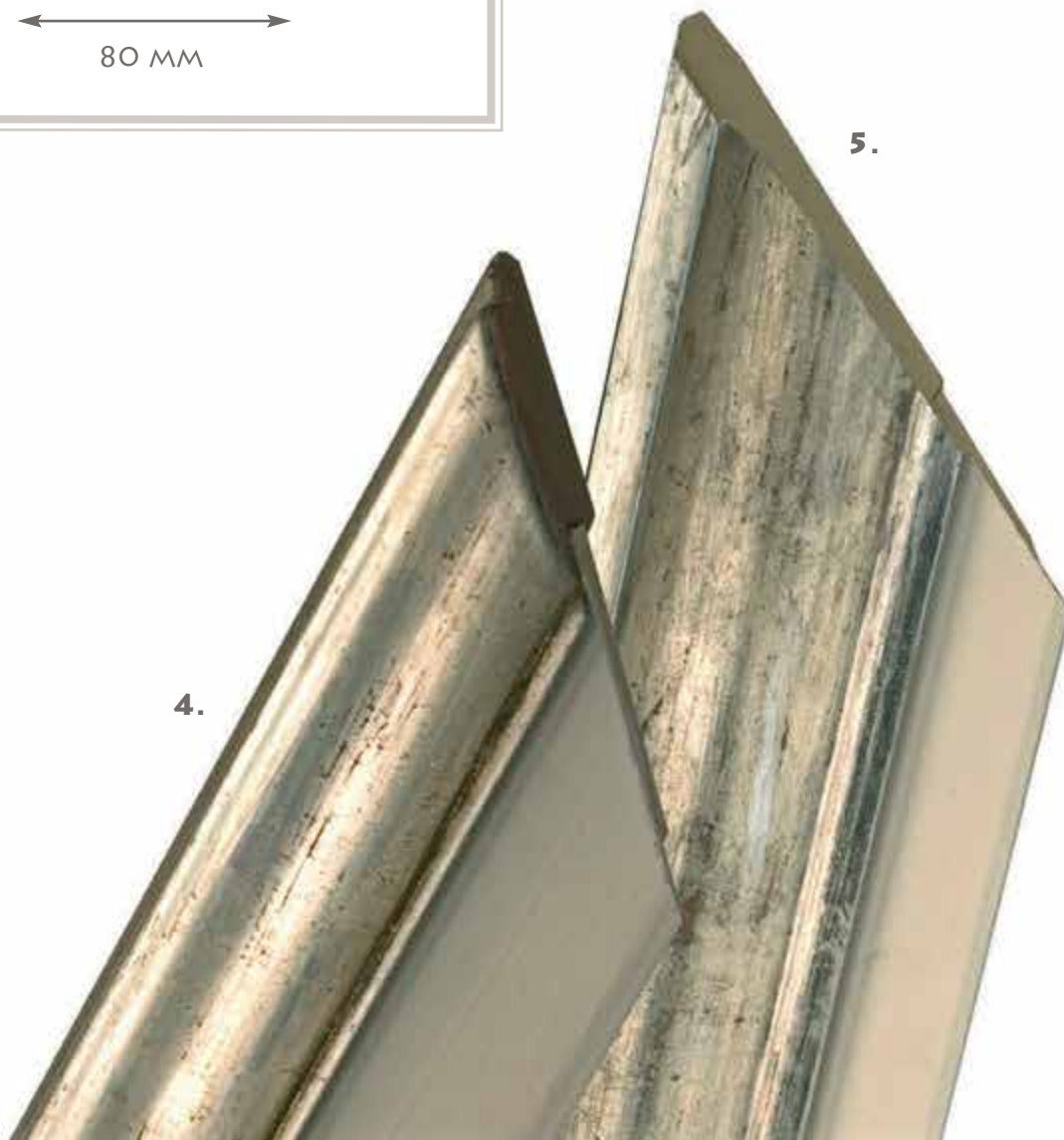
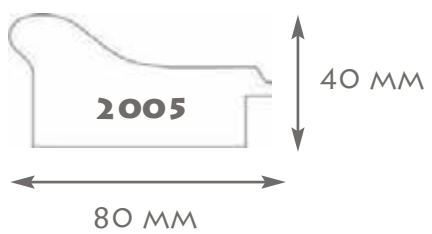
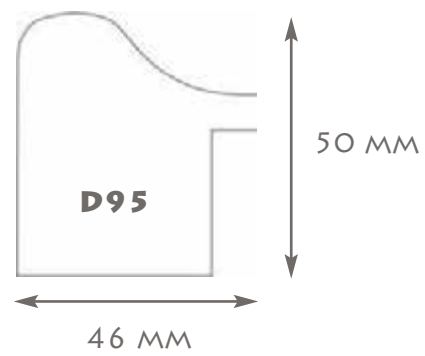
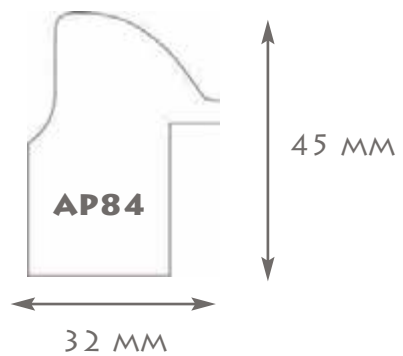
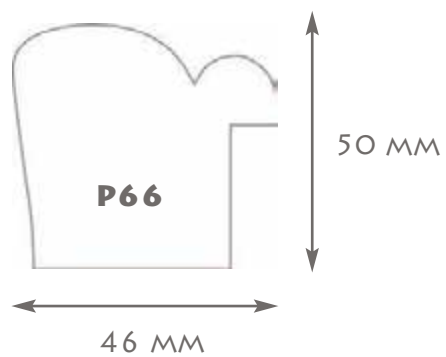
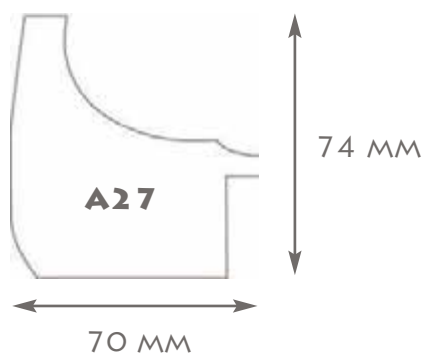

Dei
ART. DE PISIS



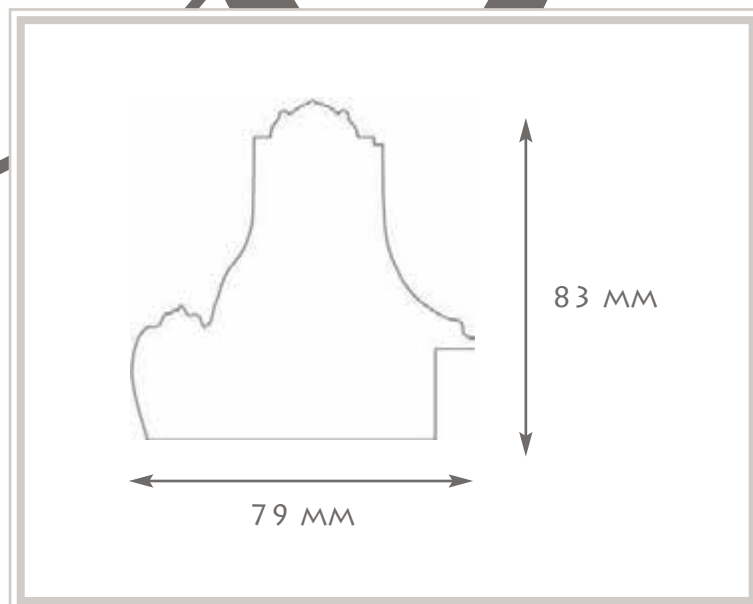

FINITURE DISPONIBILI / AVAILABLE FINISH:

PAG.101

1. ART. DE PISIS ORO / GOLD DE PISIS



ART. 98

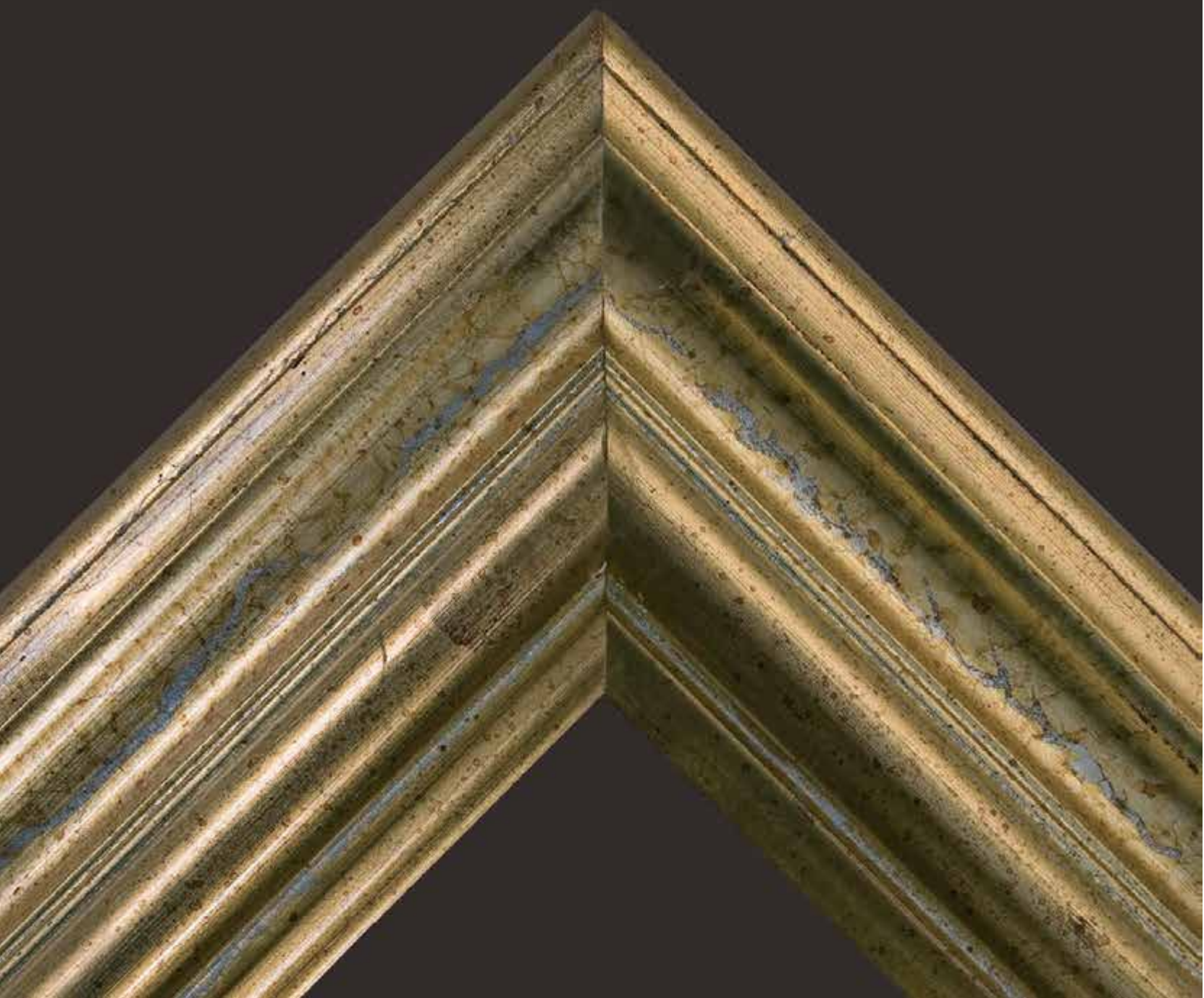

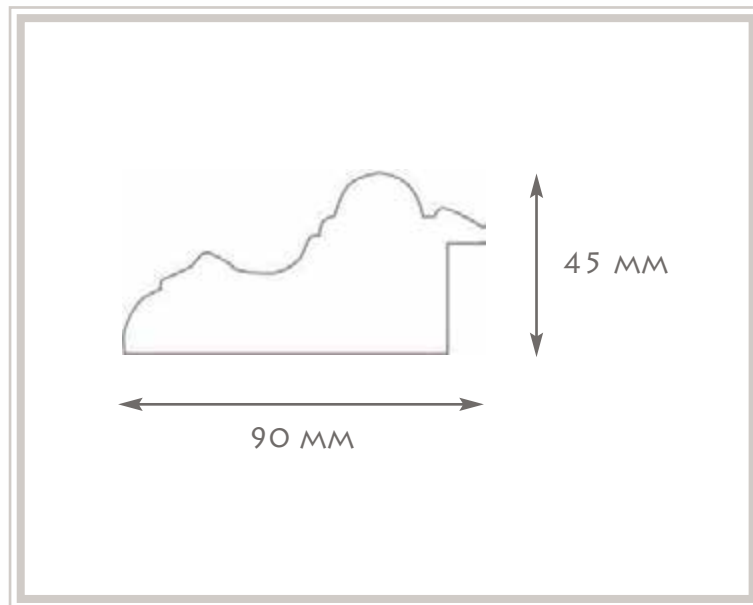

FINITURE DISPONIBILI / AVAILABLE FINISH:

1. ART. 98 ARGENTO / SILVER 98

2. ART. 98 ORO / GOLD 98

PAG.103

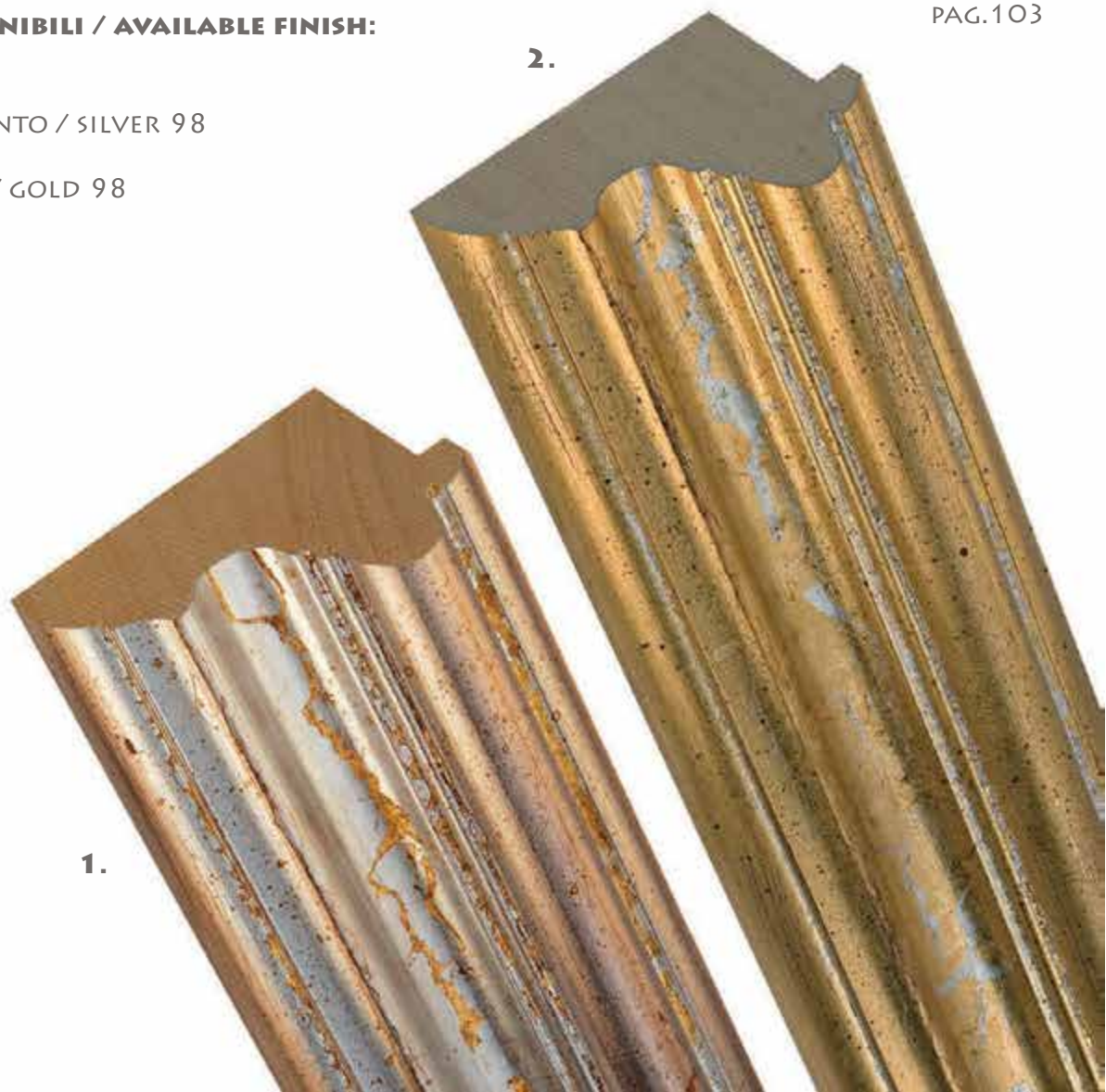

ART. 100 LAV.

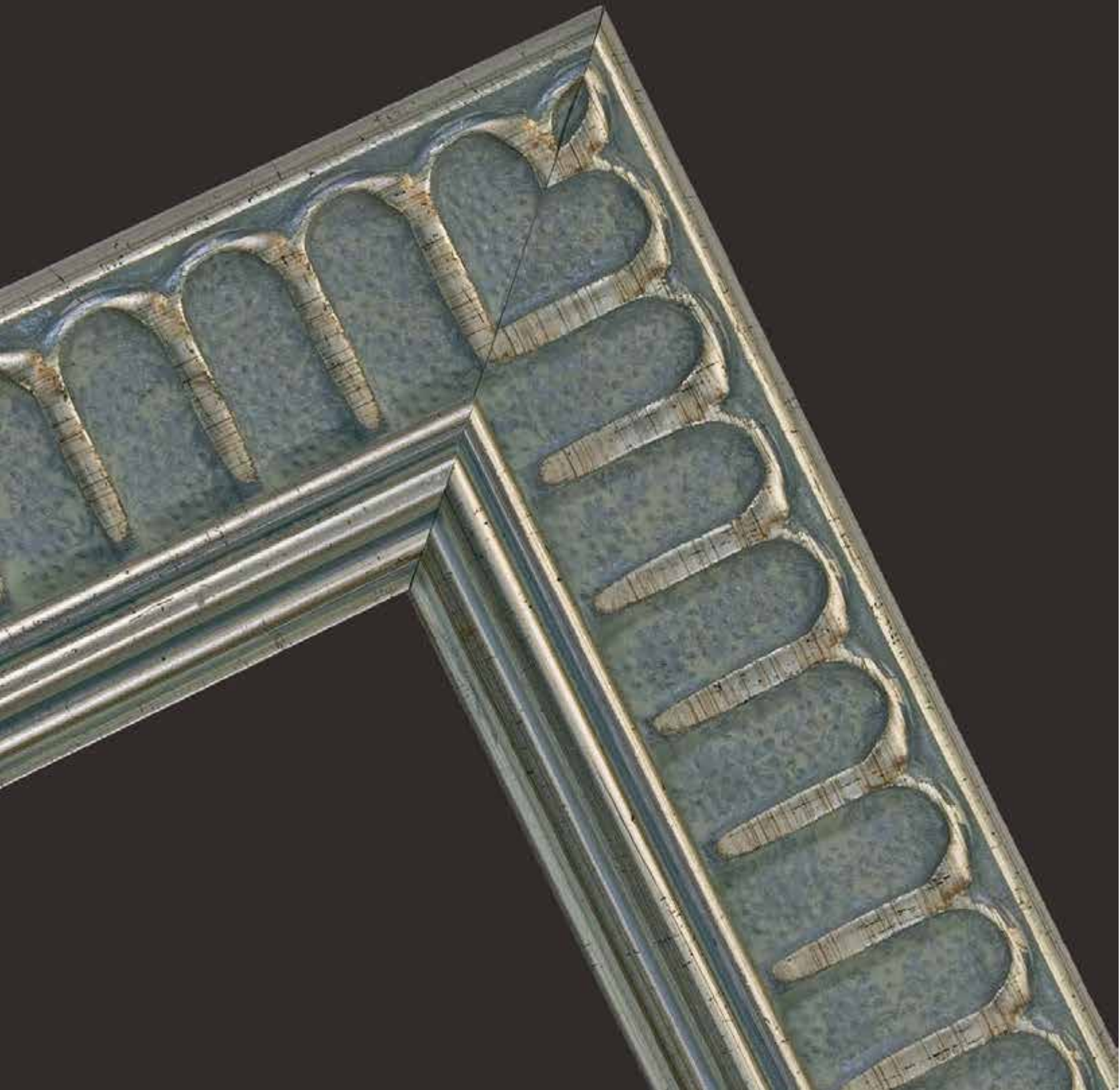

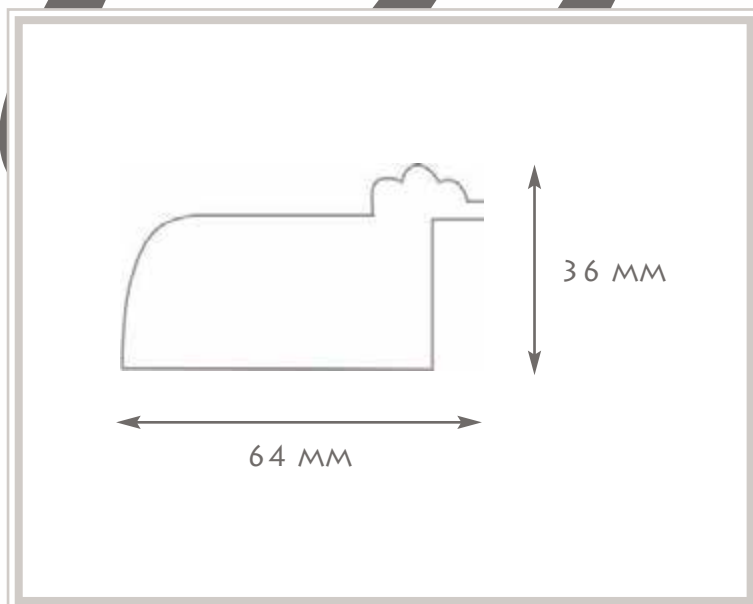

FINITURE DISPONIBILI / AVAILABLE FINISH:

1. ART. 100 LAVORATA ARGENTO

/ SILVER FASHIONED 100

2. ART. 100 LAVORATA ORO

/ GOLD FASHIONED 100

PAG.105

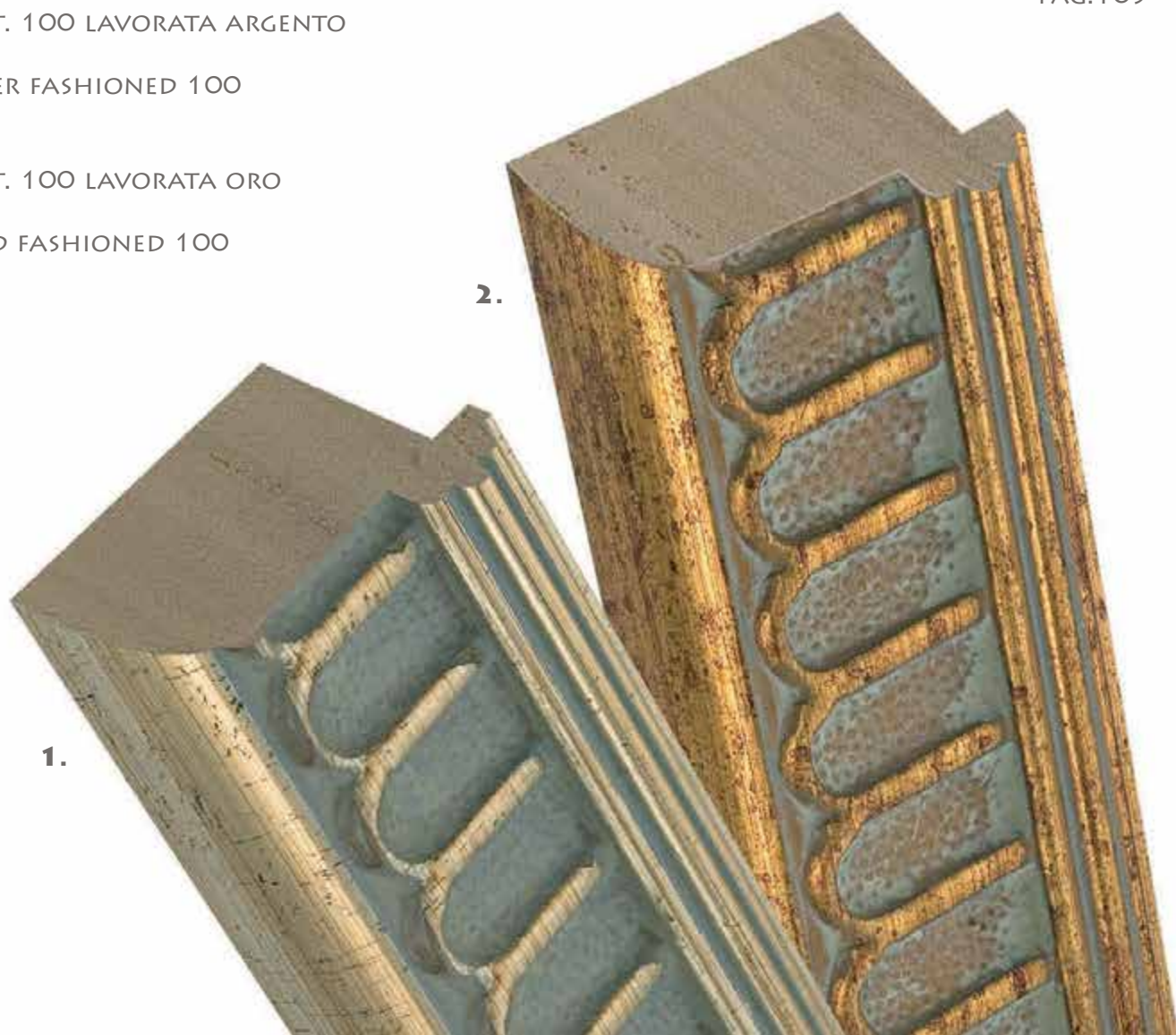

ART. 110 LAV.



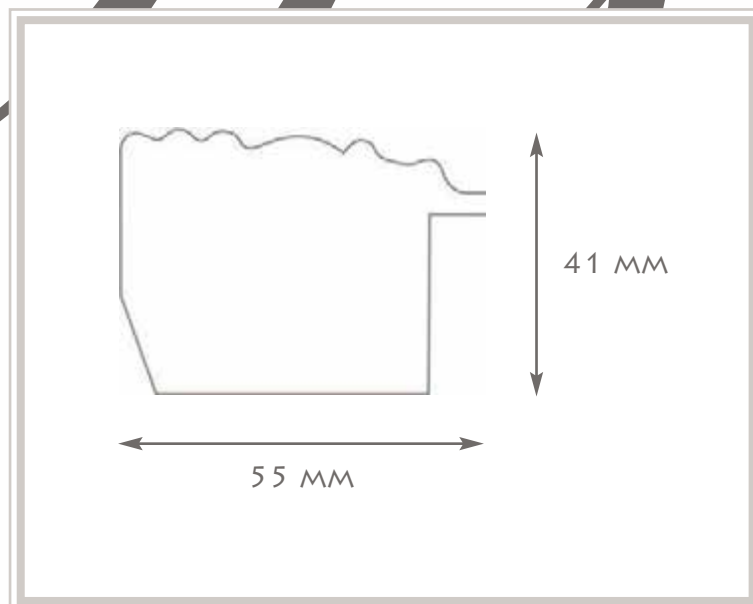

FINITURE DISPONIBILI / AVAILABLE FINISH:

PAG.107

1. ART. 110 LAVORATA ARGENTO

/ SILVER FASHIONED 110

2. ART. 110 LAVORATA ORO

/ GOLD FASHIONED 110

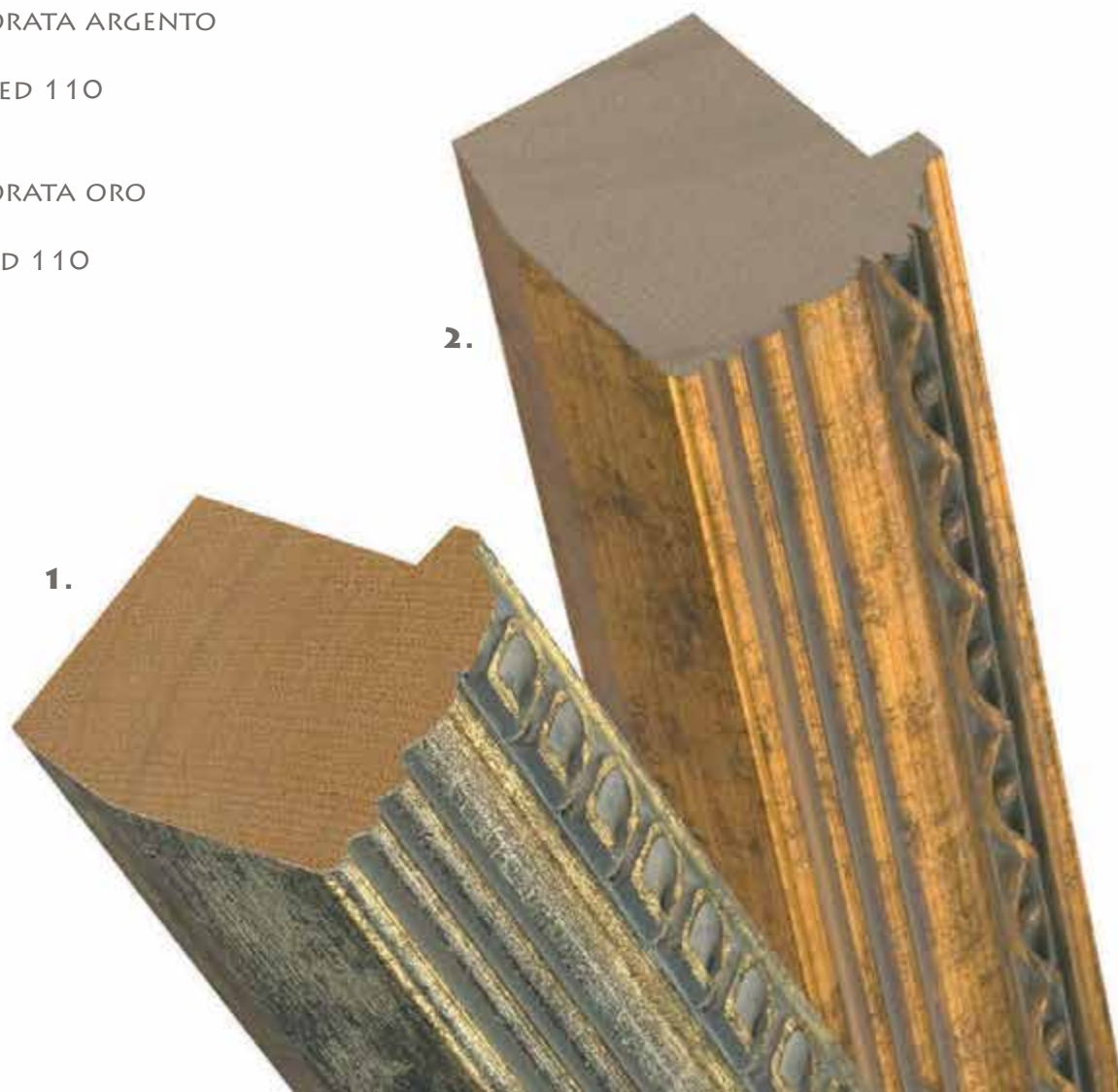

ART. 196

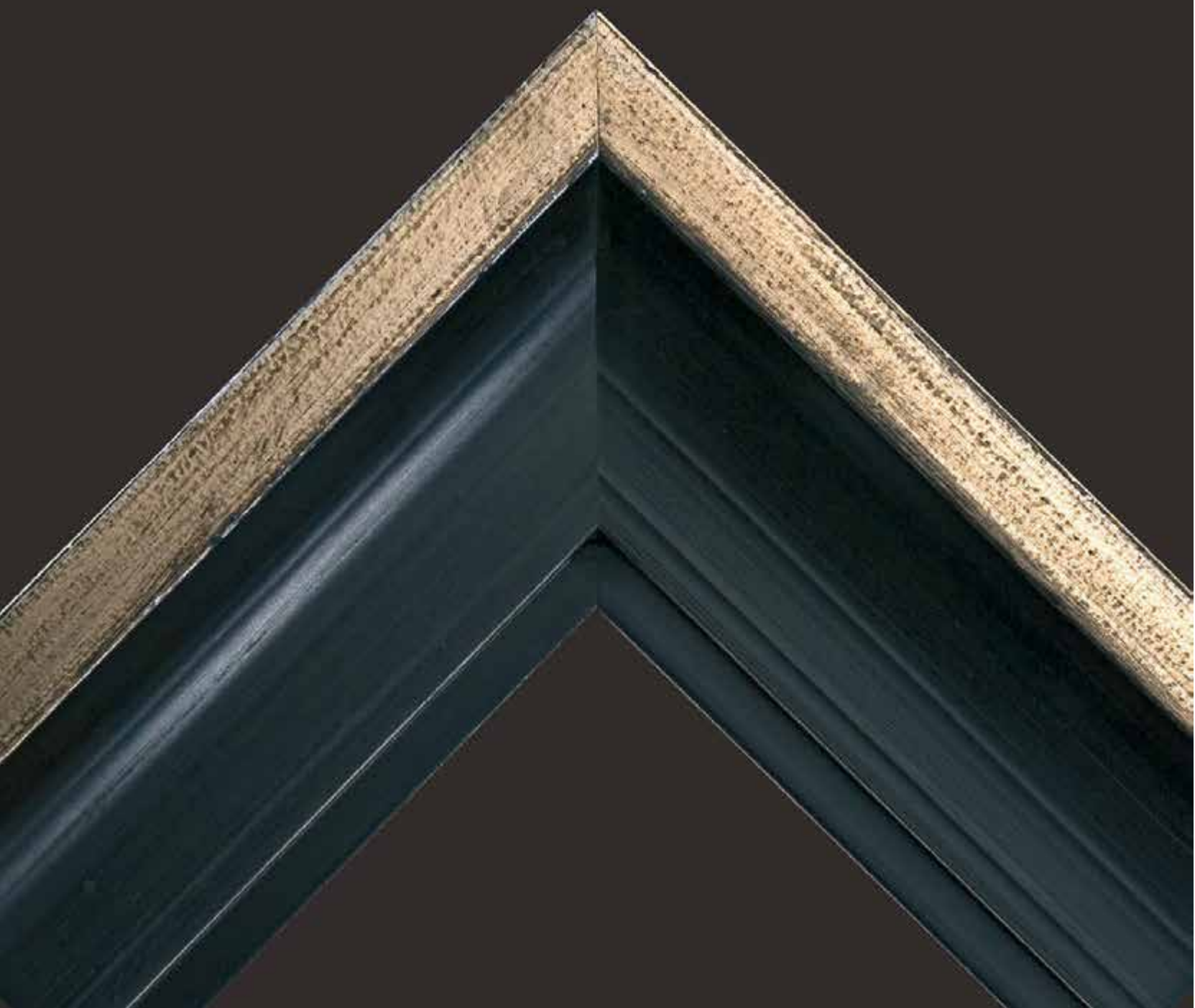

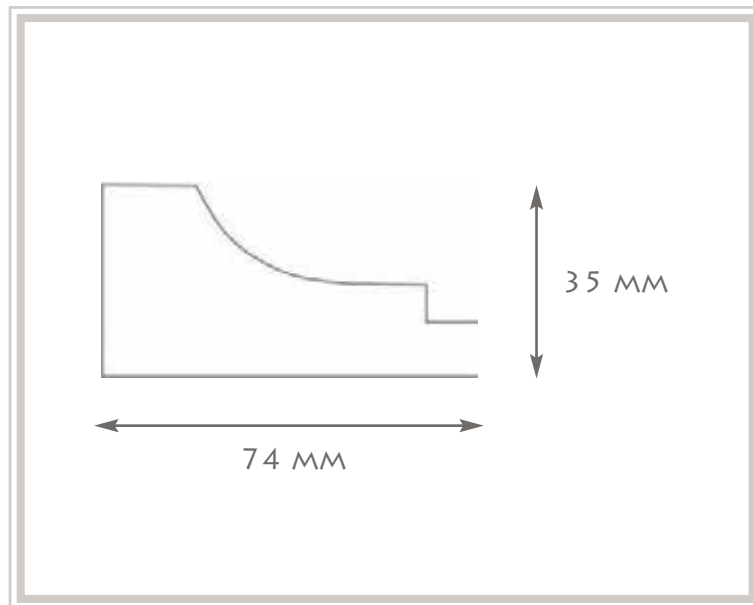

FINITURE DISPONIBILI / AVAILABLE FINISH:

1. ART. 196 AVORIO / IVORY 196
2. ART. 196 NERO / BLACK 196

PAG.109

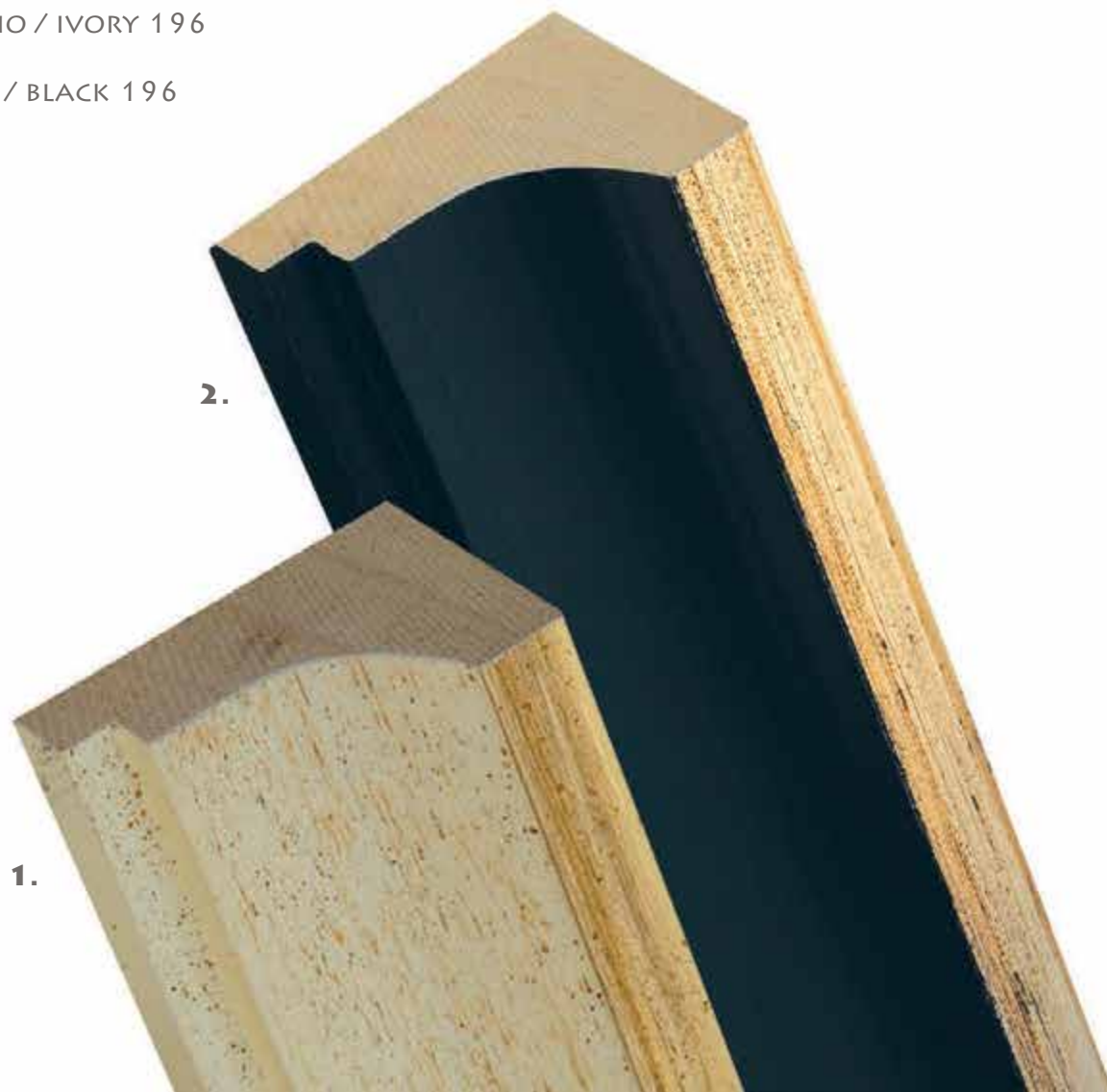



ART. 207

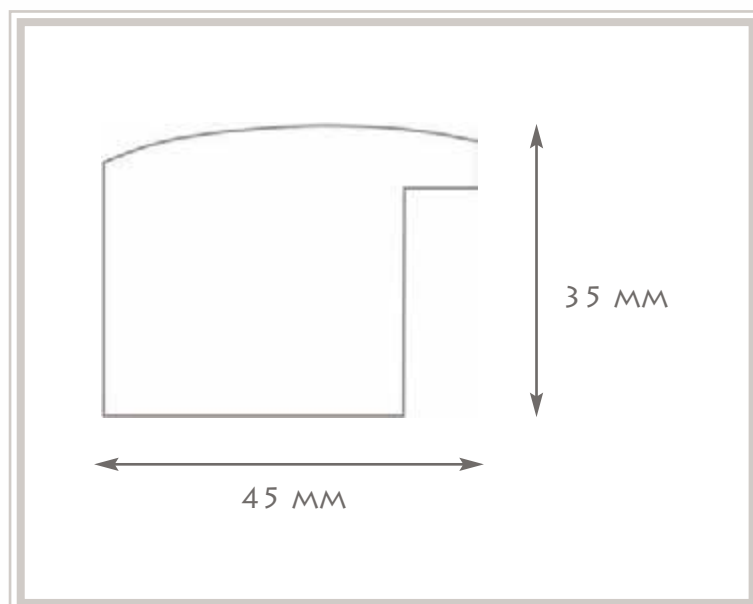

FINITURE DISPONIBILI / AVAILABLE FINISH:

1. ART. 207 MATTONE / COLOUR BRIK RED 207
2. ART. 207 VERDE / GREEN 207
3. ART. 207 WENGÉ / WENGÉ 207
4. ART. 207 SALMONE / SALMON PINK 207

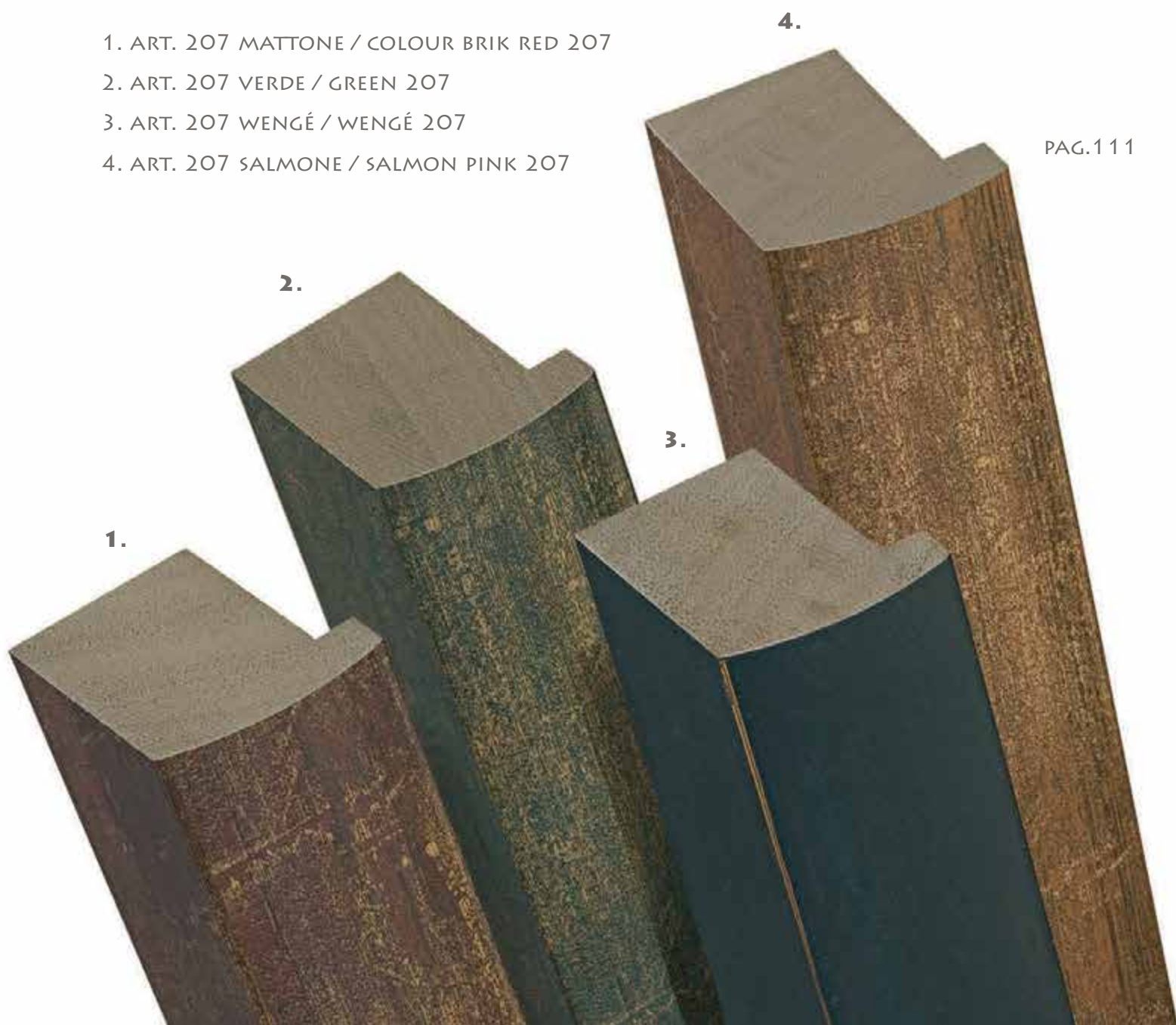

ART. 208



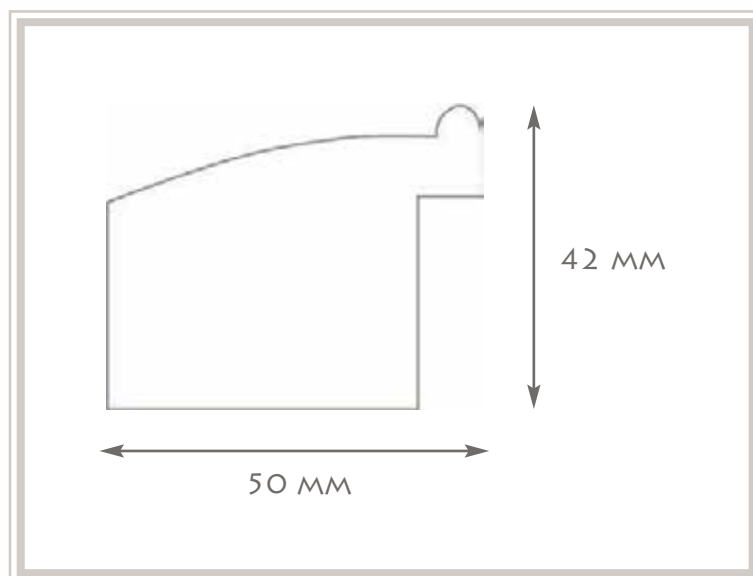

FINITURE DISPONIBILI / AVAILABLE FINISH:

1. ART. 208 PRUGNA / PLUM COLOURED 208
2. ART. 208 VERDE / GREEN 208
3. ART. 208 MATTONE / COLOUR BRIK RED 208
4. ART. 208 BLU / BLUE 208



ART. 258



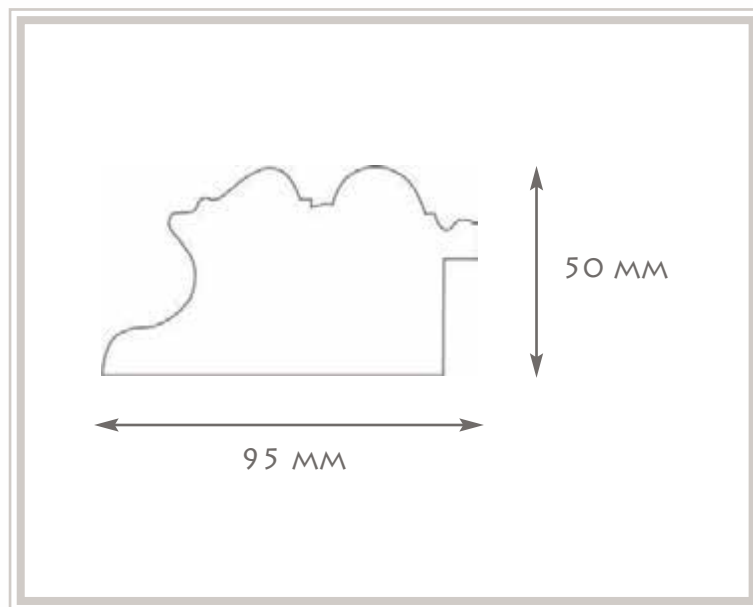

FINITURE DISPONIBILI / AVAILABLE FINISH:

PAG.115

1. ART. 258 ORO / GOLD 258

2. ART. 258 ARGENTO / SILVER 258



ART. 319



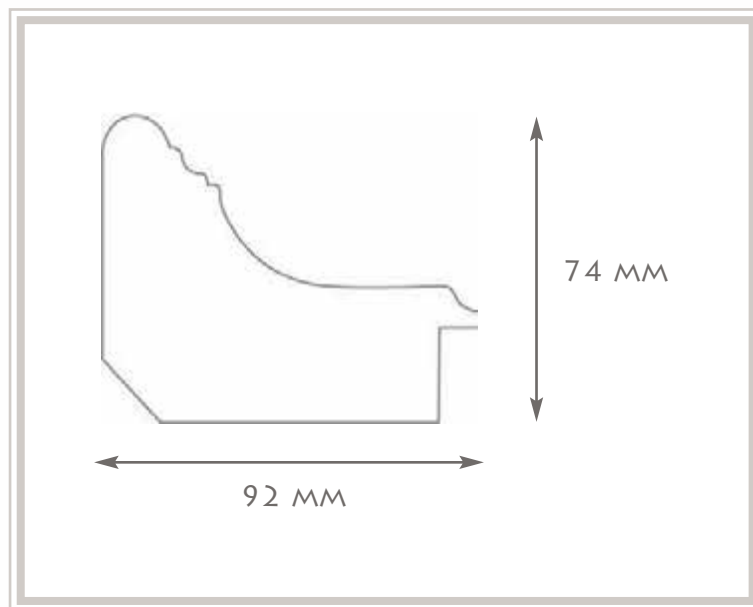

FINITURE DISPONIBILI / AVAILABLE FINISH:

PAG.117

1. ART. 319 VERDE / GREEN 319
2. ART. 319 ROSSO / RED 319
3. ART. 319 BLU / BLUE 319

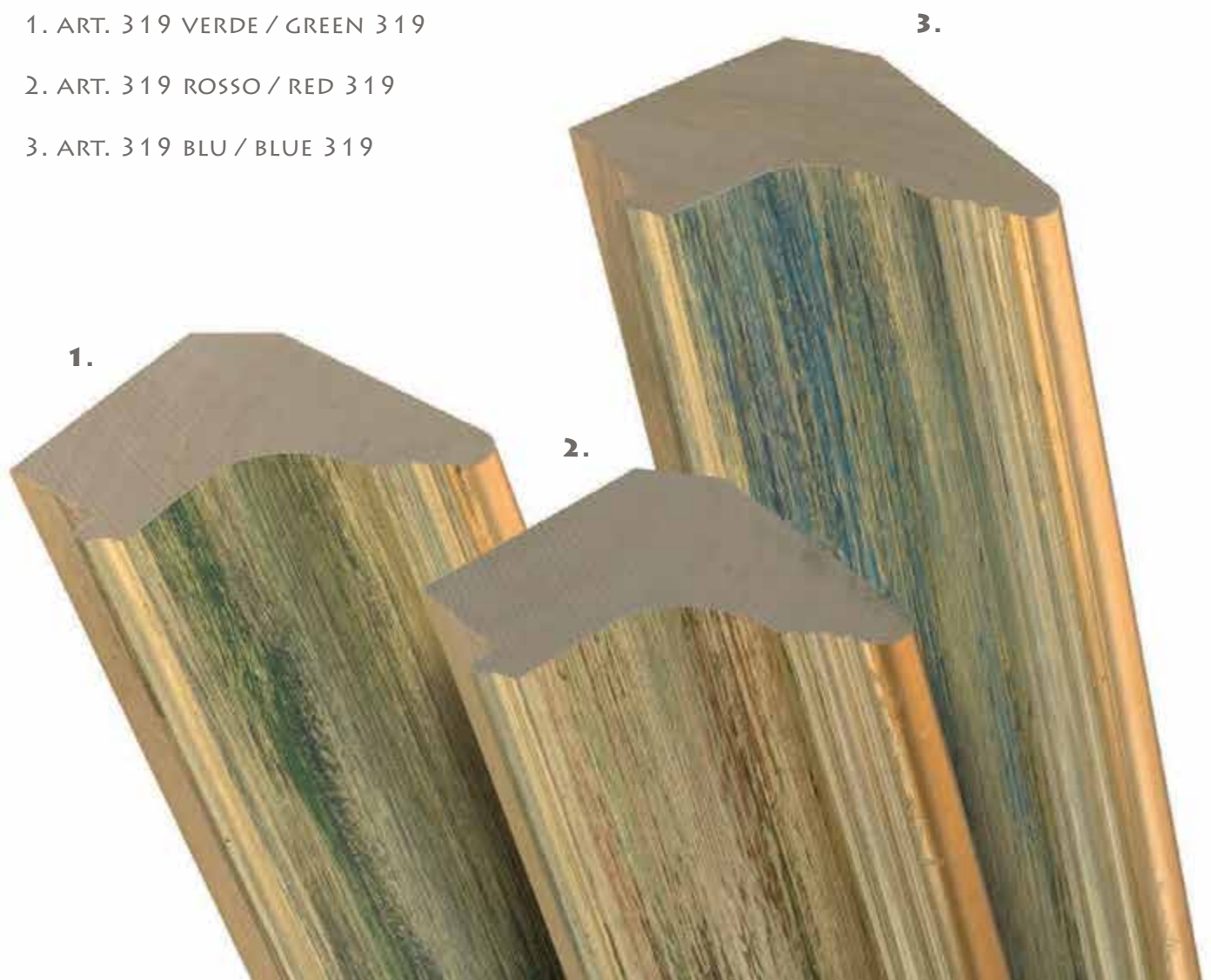

ART. 320



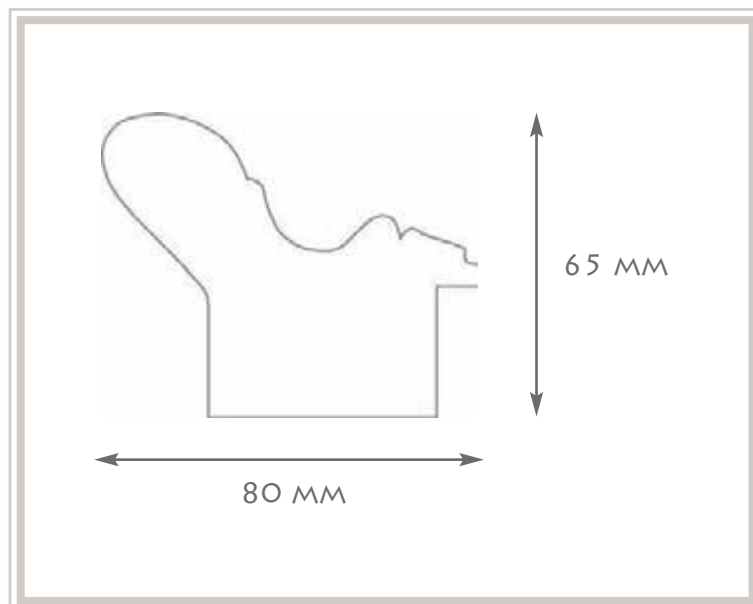

FINITURE DISPONIBILI / AVAILABLE FINISH:

PAG.119

1. ART. 320 ARGENTO / SILVER 320

2. ART. 320 ORO / GOLD 320

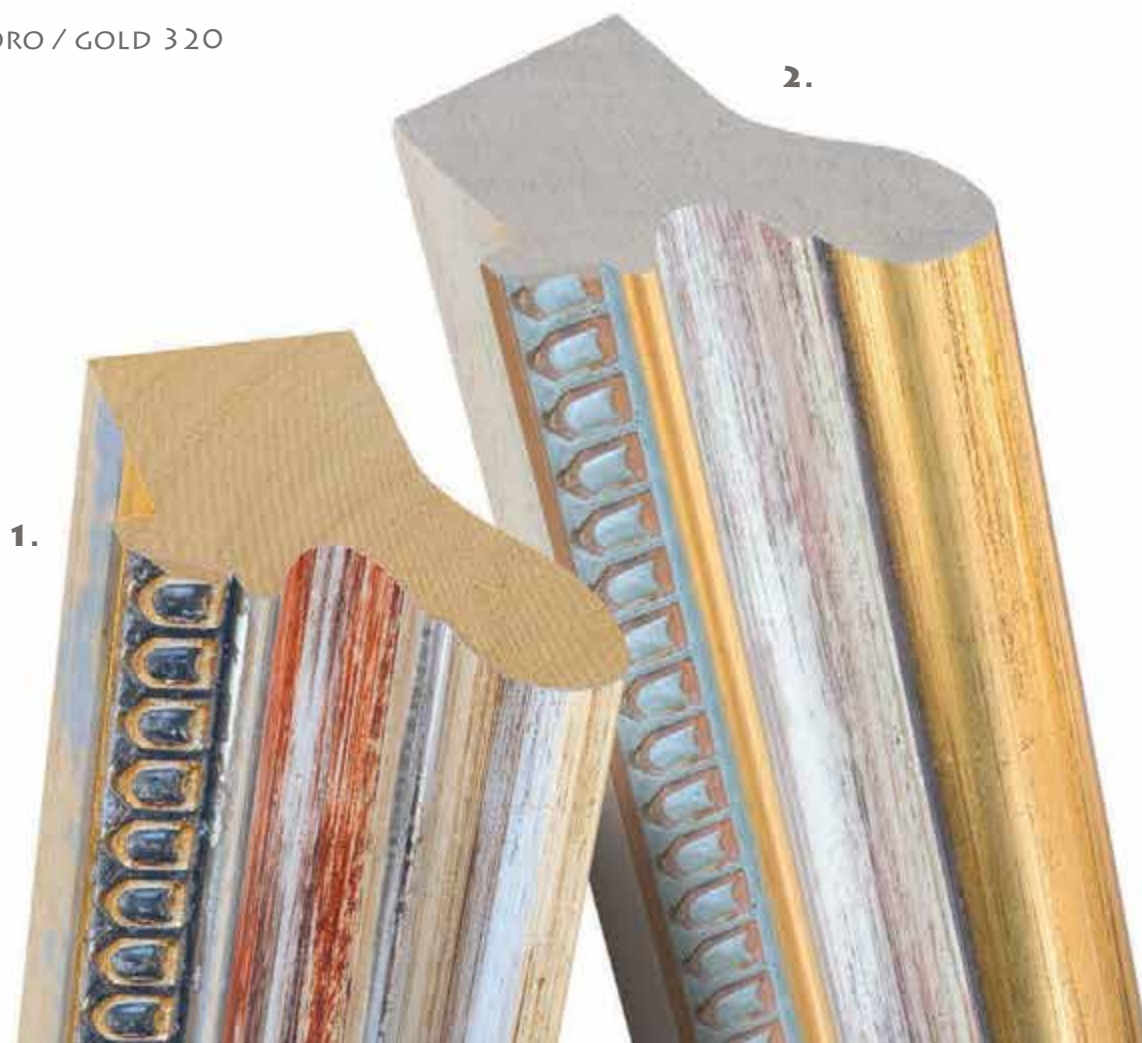

ART. 340



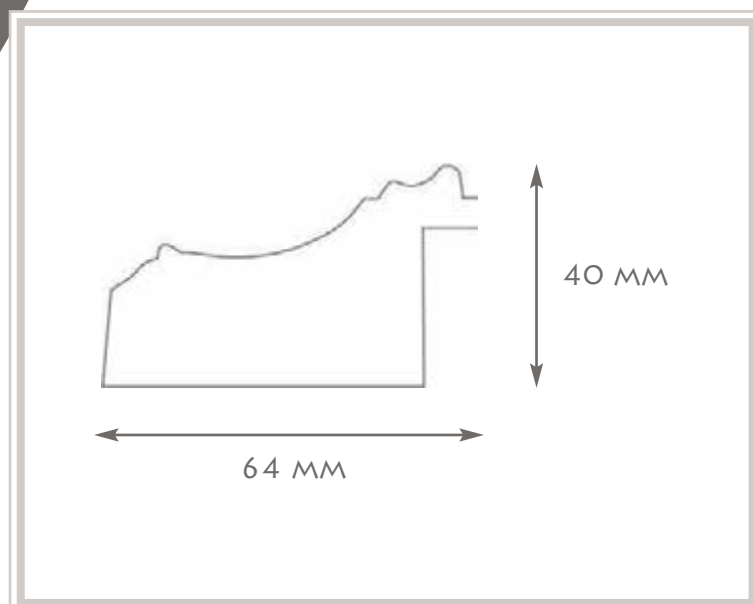

FINITURE DISPONIBILI / AVAILABLE FINISH:

1. ART. 340 SALMONE / SALMON PINK 340
2. ART. 340 BLU / BLUE 340
3. ART. 340 MATTONE / COLOUR BRIK RED 340
4. ART. 340 VERDE / GREEN 340

4.

PAG.121

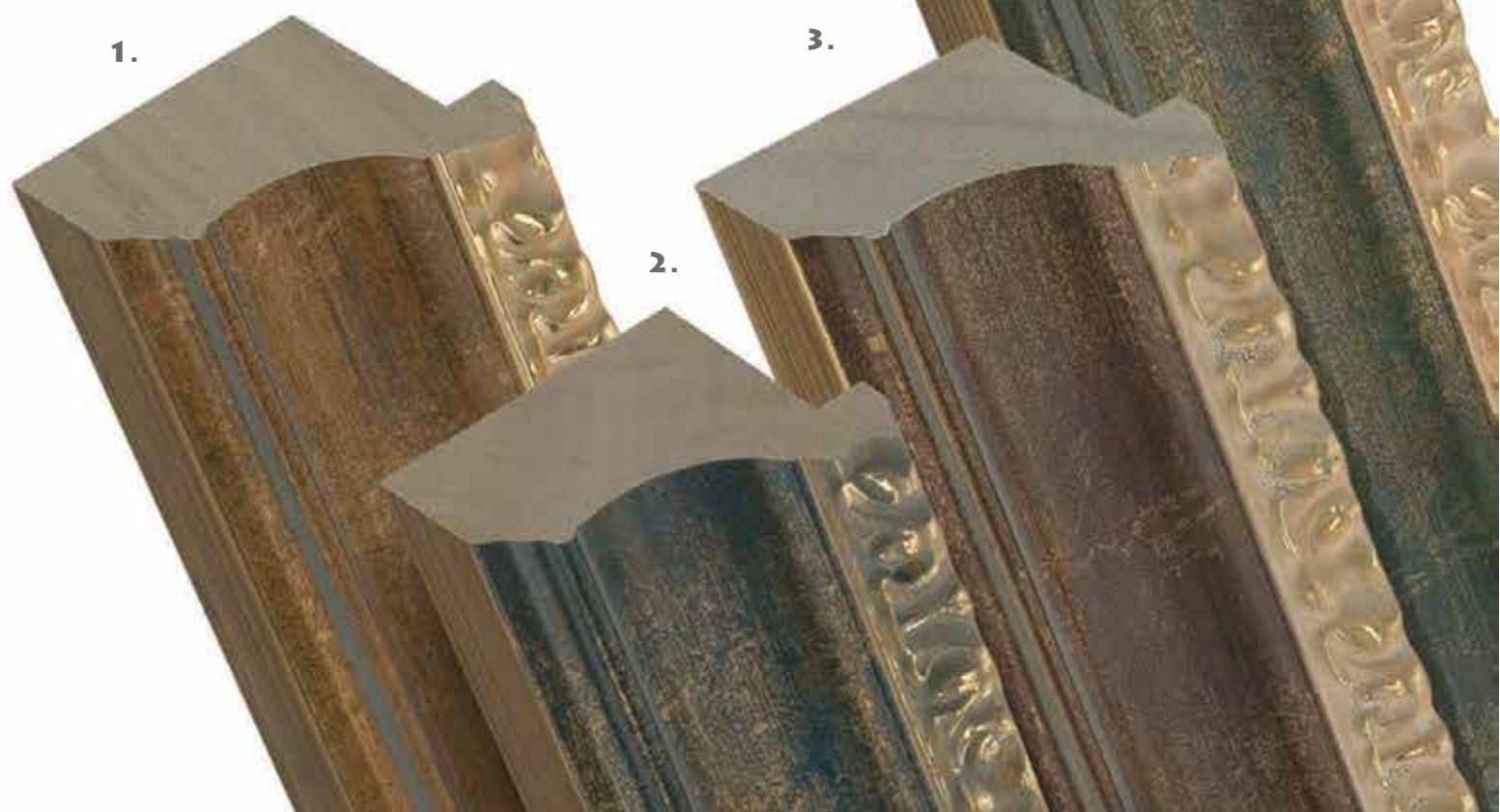

ART. 350

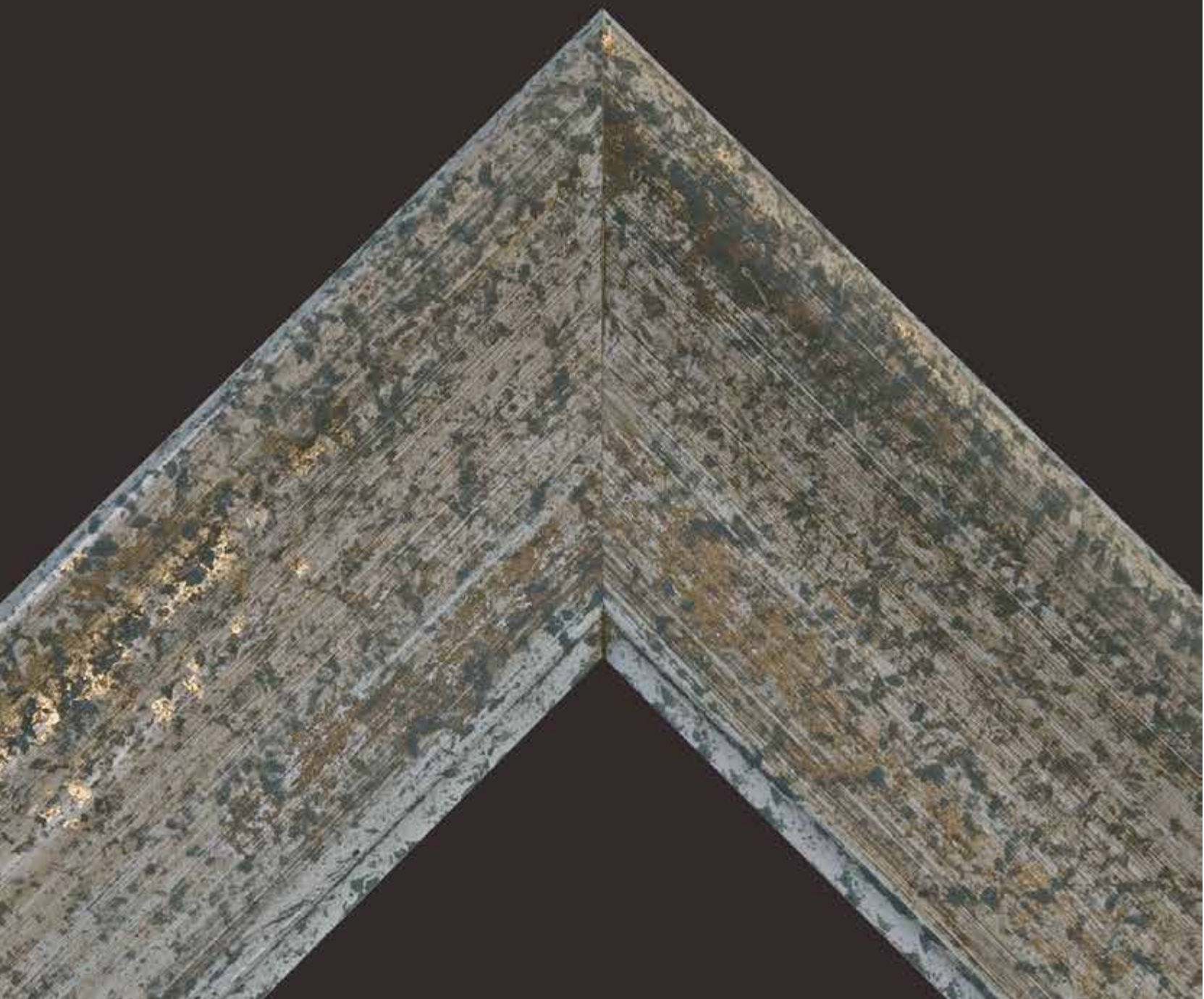

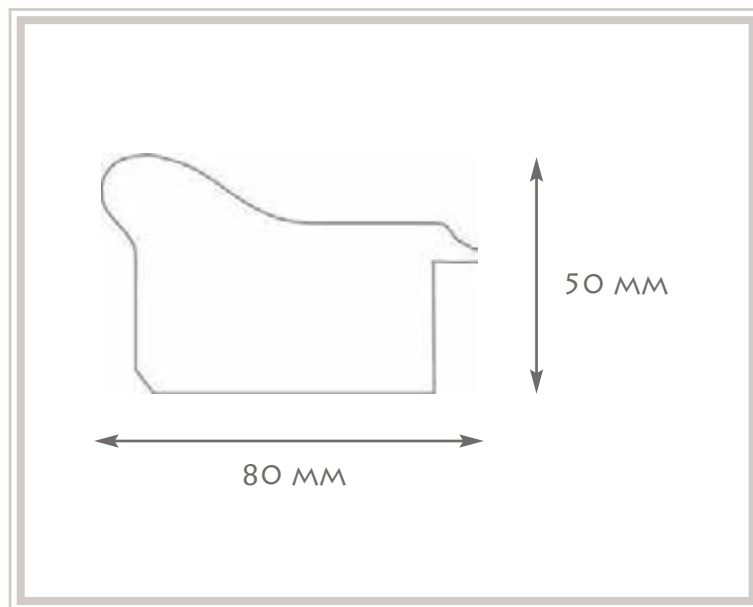

FINITURE DISPONIBILI / AVAILABLE FINISH:

1. ART. 350 NERO / BLACK 350

2. ART. 350 AVORIO / IVORY 350

PAG.123



ART. 360



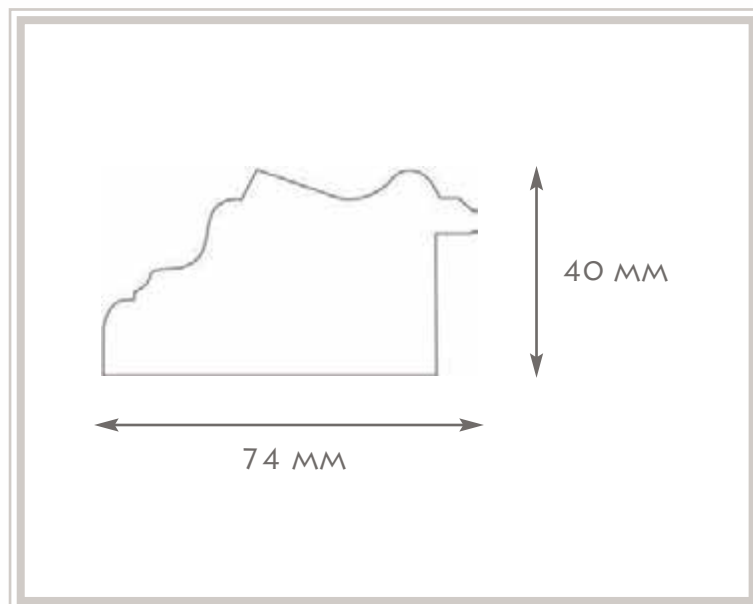

FINITURE DISPONIBILI / AVAILABLE FINISH:

PAG.125

1. ART. 360 ARGENTO / SILVER 360

2. ART. 360 ORO / GOLD 360



400

ART. 400



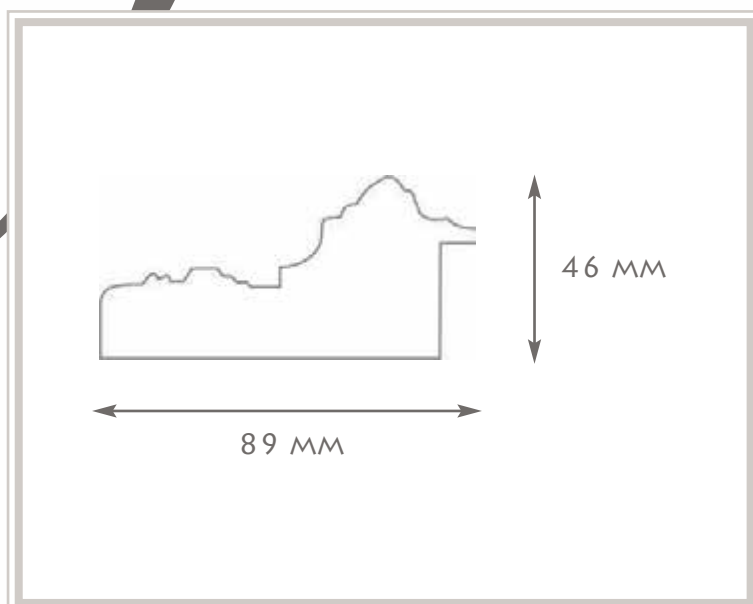

FINITURE DISPONIBILI / AVAILABLE FINISH:

1. ART. 400 ORO / GOLD 400
2. ART. 400 ARGENTO / SILVER 400

PAG.127



ART. 600



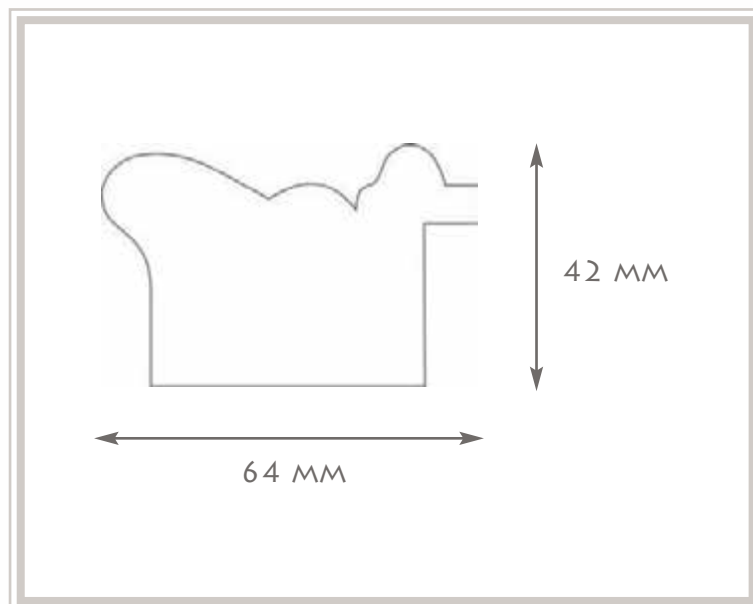

FINITURE DISPONIBILI / AVAILABLE FINISH:

1. ART. 600 ARGENTO / SILVER 600

2. ART. 600 ORO / GOLD 600

PAG.129

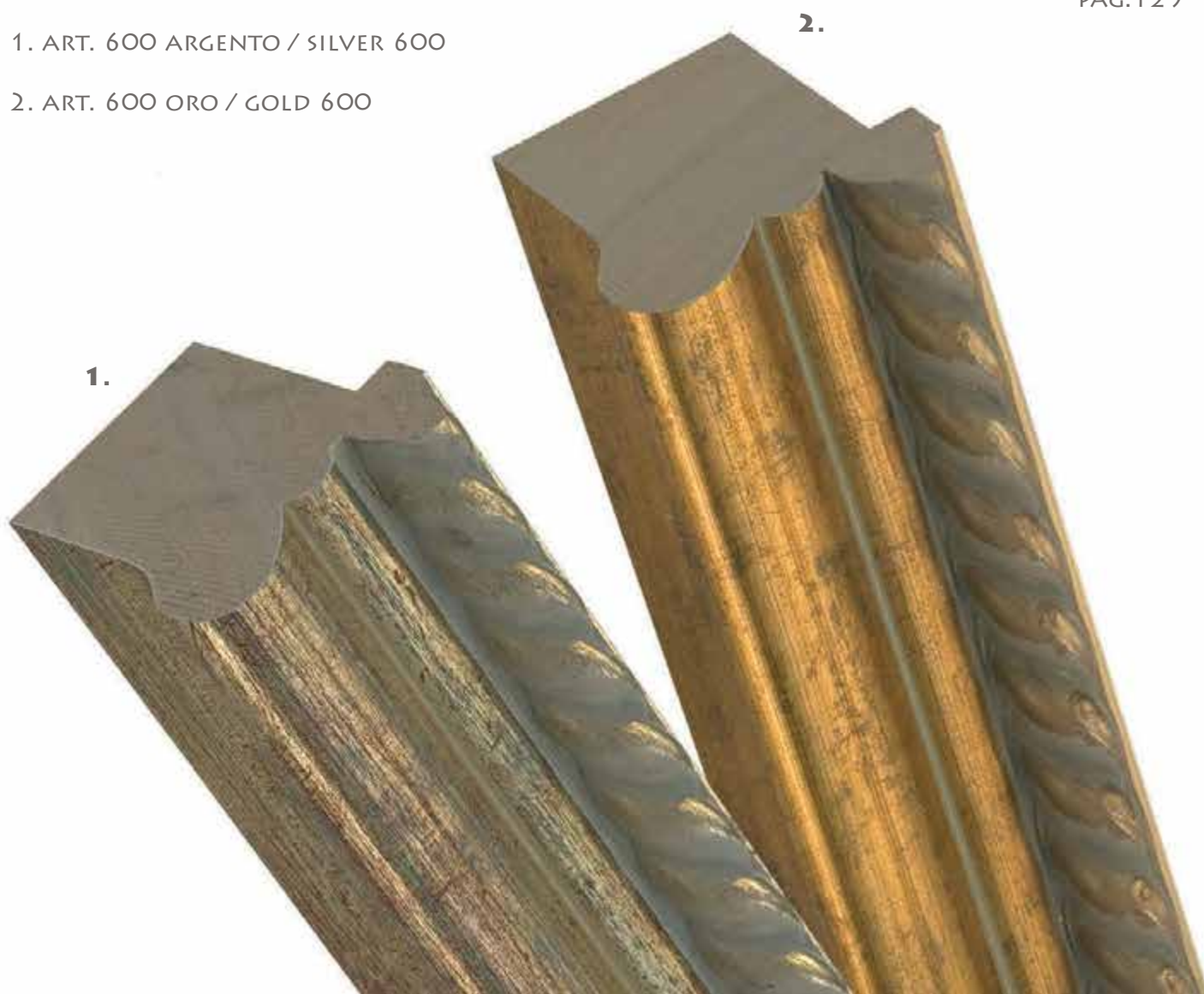

ART. 650



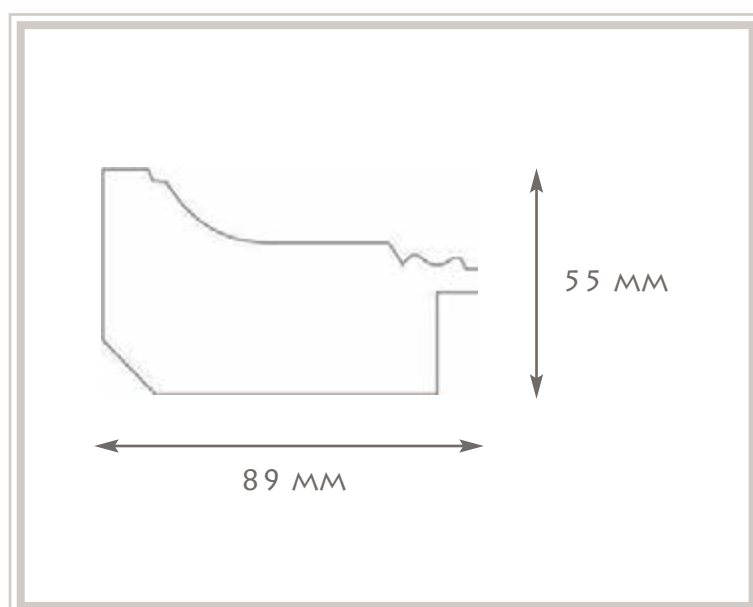

FINITURE DISPONIBILI / AVAILABLE FINISH:

PAG.131

1. ART. 650 NERO / BLACK 650

2. ART. 650 ORO / GOLD 650

2.

1.



ART. 673



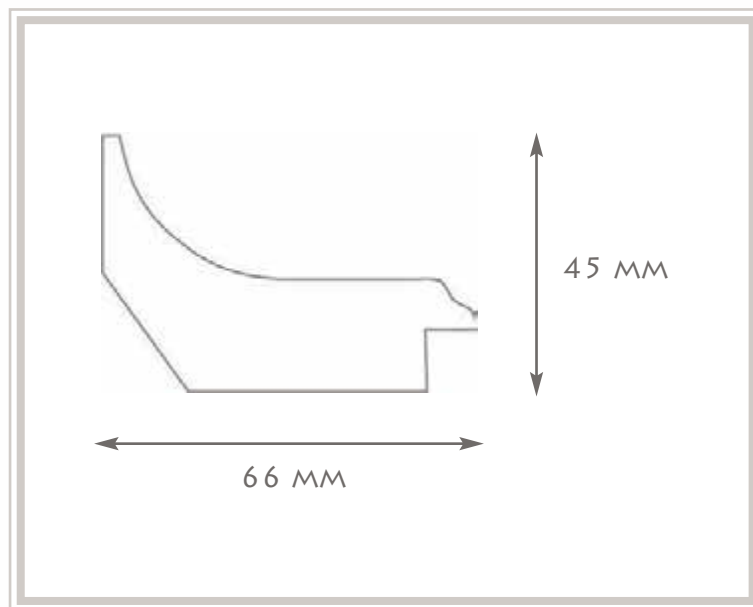

FINITURE DISPONIBILI / AVAILABLE FINISH:

PAG.133

1. ART. 673 WENGÉ / WENGÉ 673



ART. 745

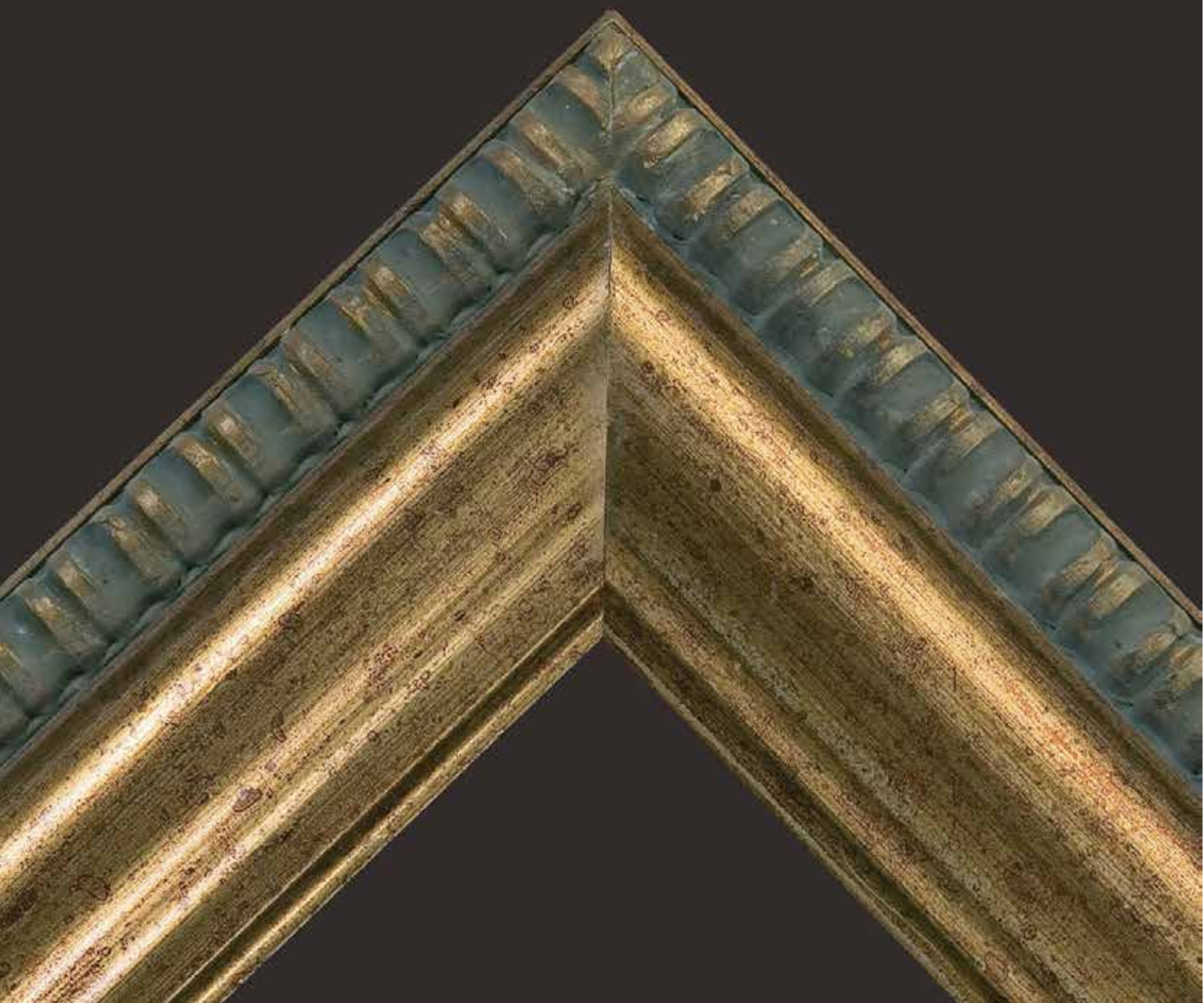

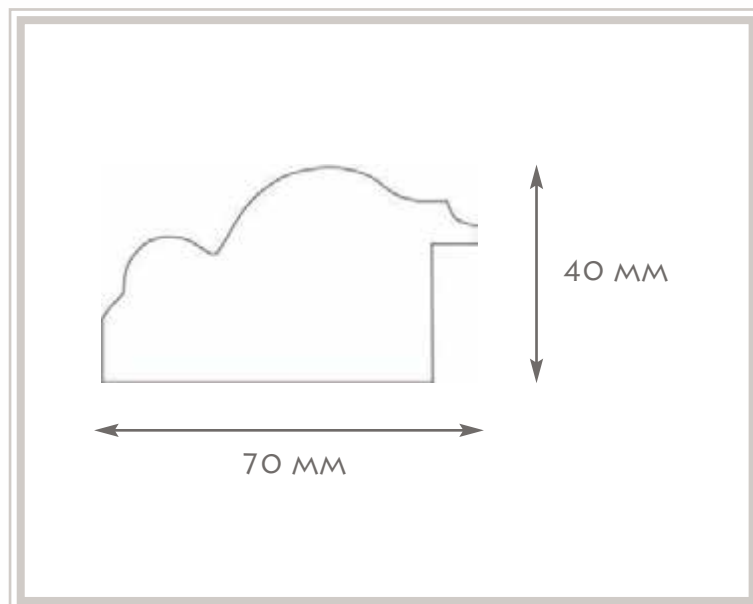

FINITURE DISPONIBILI / AVAILABLE FINISH:

1. ART. 745 ARGENTO / SILVER 745

2. ART. 745 ORO / GOLD 745

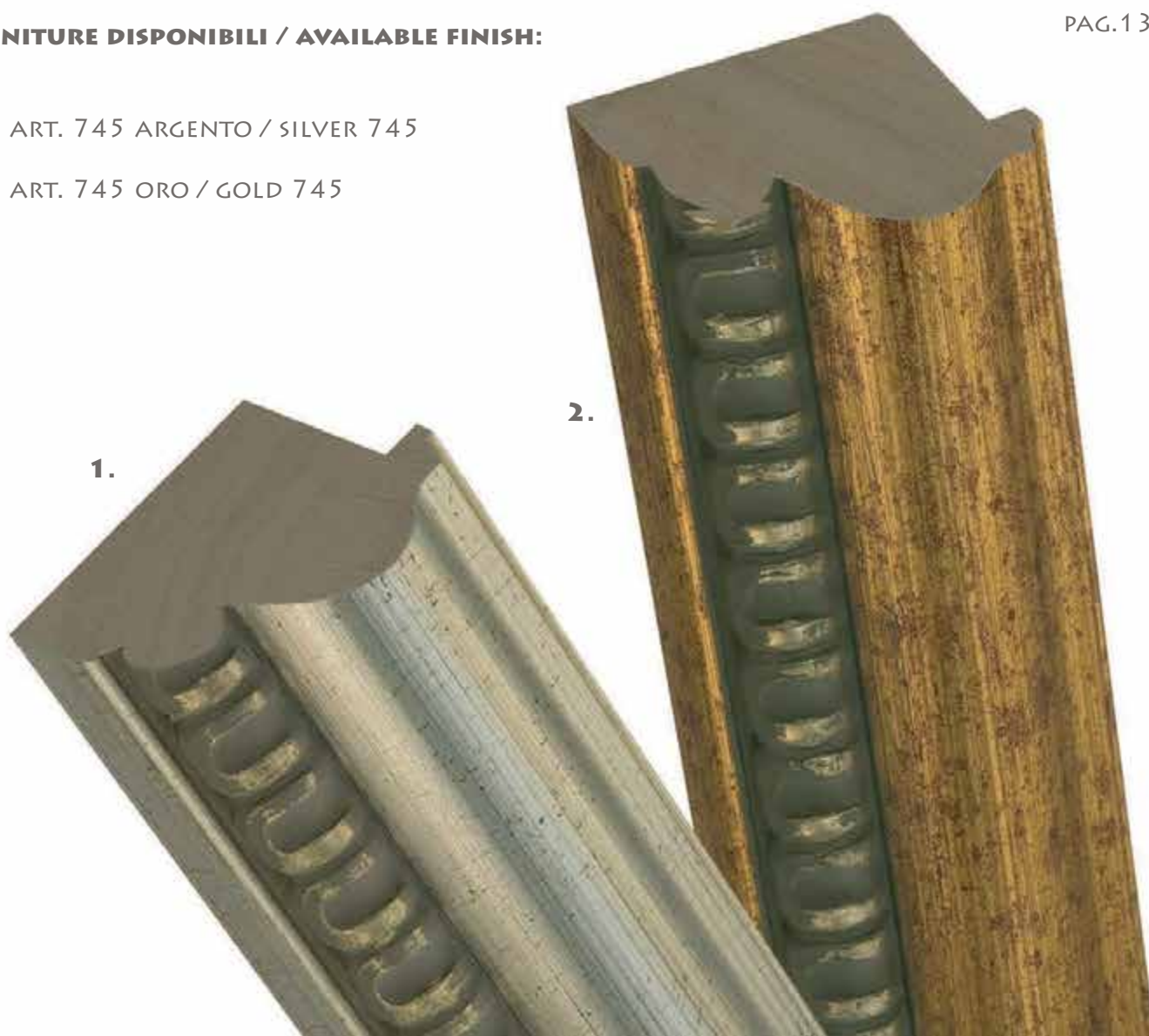

ART. 746 BIS



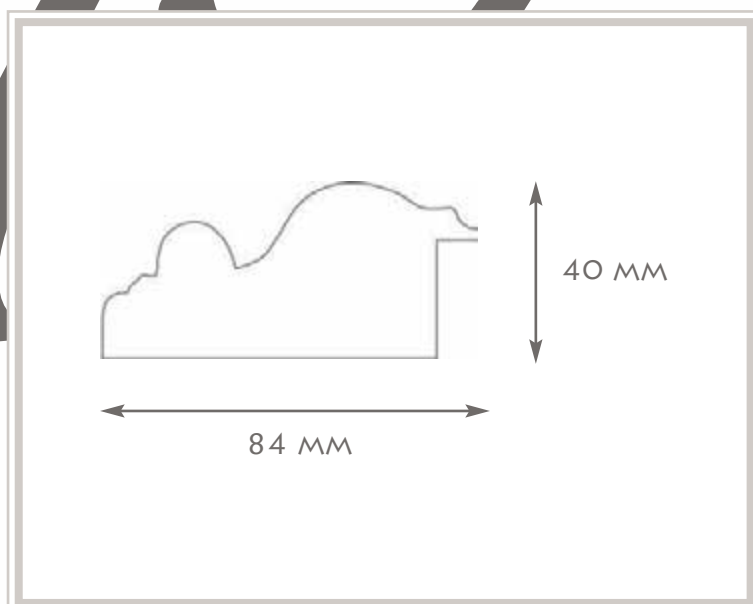

FINITURE DISPONIBILI / AVAILABLE FINISH:

1. ART. 746 BIS ORO / GOLD 746 BIS

2. ART. 746 BIS ARGENTO / SILVER 746 BIS

2.

PAG.137

1.



ART. 950



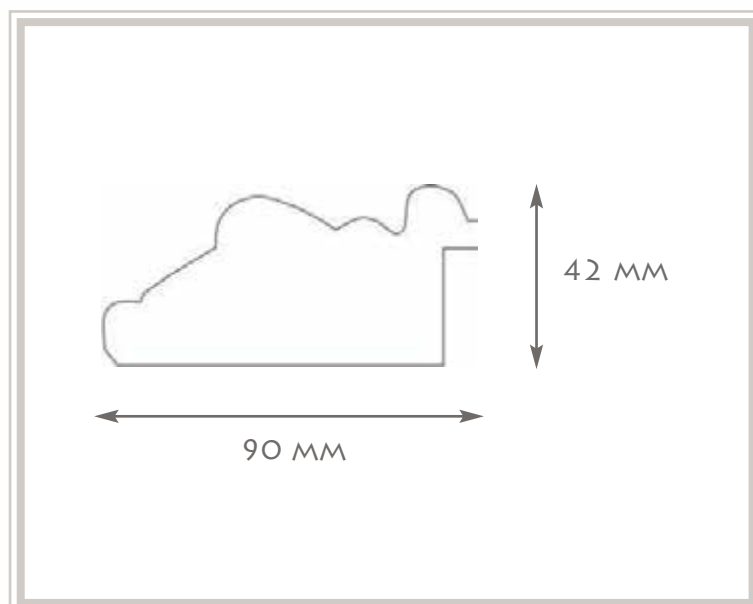

FINITURE DISPONIBILI / AVAILABLE FINISH:

1. ART. 950 ARGENTO / SILVER 950

2. ART. 950 ORO / GOLD 950

PAG.139



ART. 2003



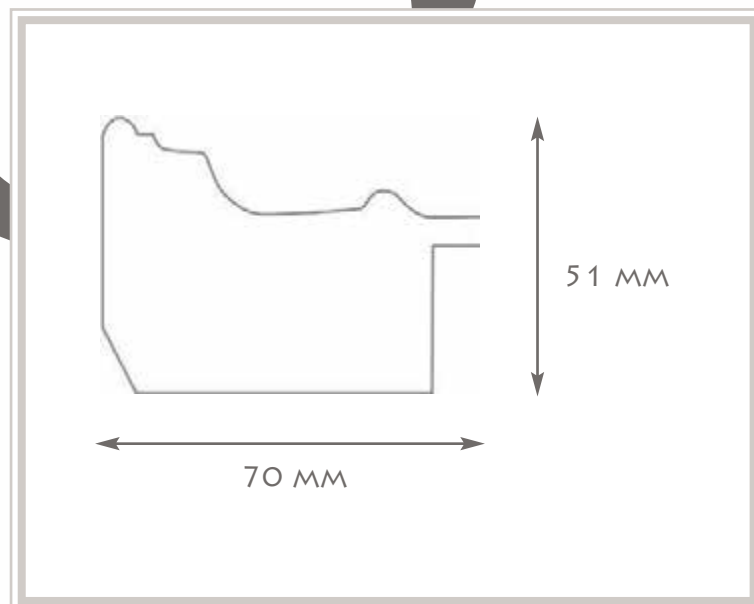

FINITURE DISPONIBILI / AVAILABLE FINISH:

PAG.141

1. ART. 2003 ORO / GOLD 2003

6. ART. 2003 ARGENTO / SILVER 2003



ART. 2003 LAV.

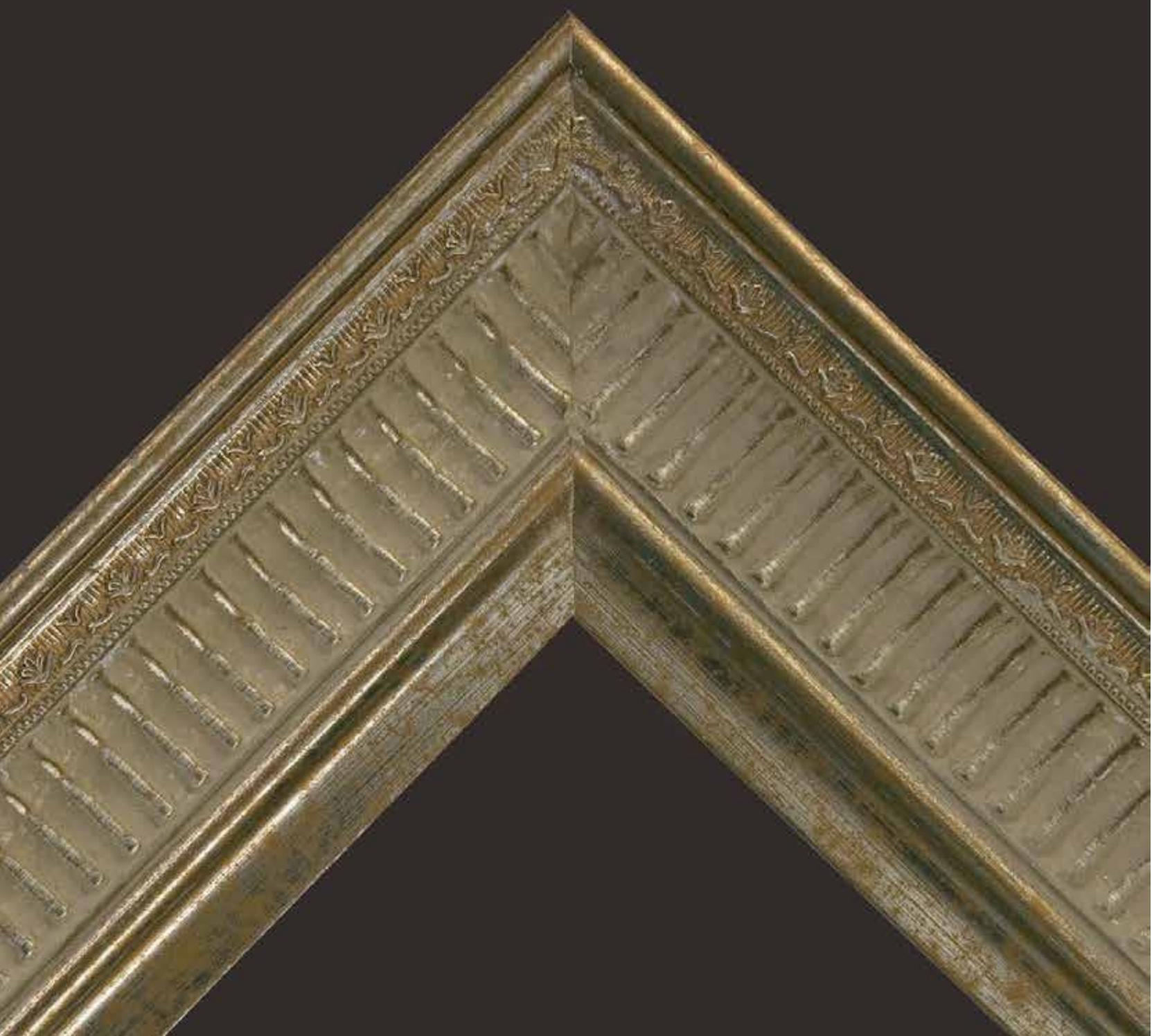

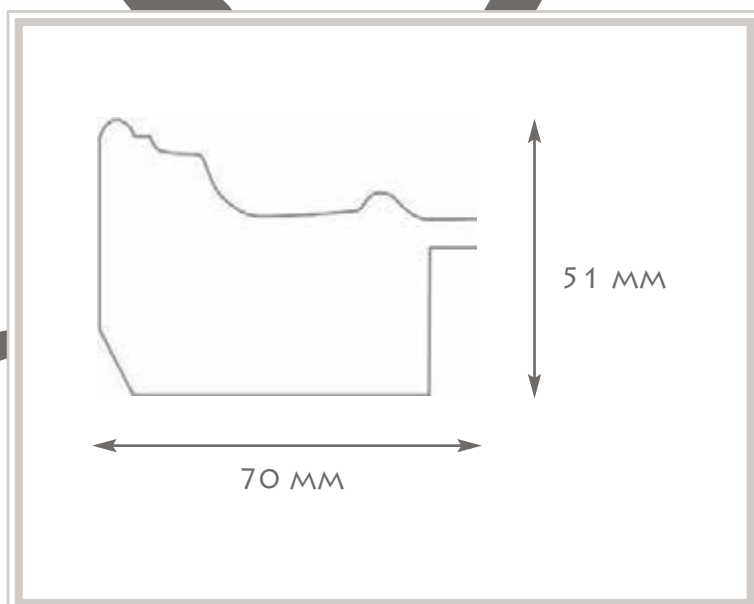

FINITURE DISPONIBILI / AVAILABLE FINISH:

1. ART. 2003 LAVORATA ARGENTO

/ SILVER FASHIONED 2003

2. ART. 2003 LAVORATA ORO

/ GOLD FASHIONED 2003

PAG.143

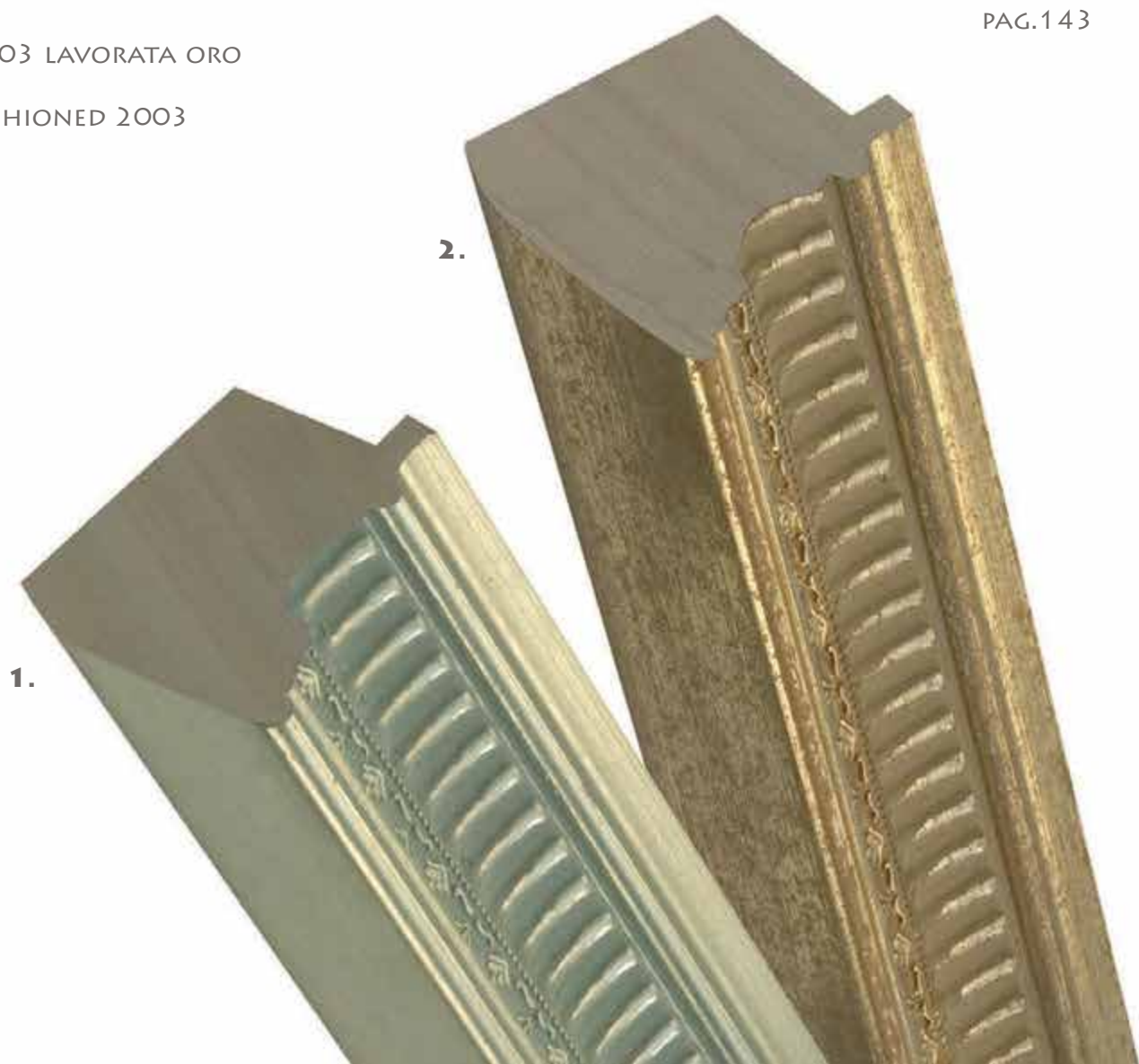

ART. 2007



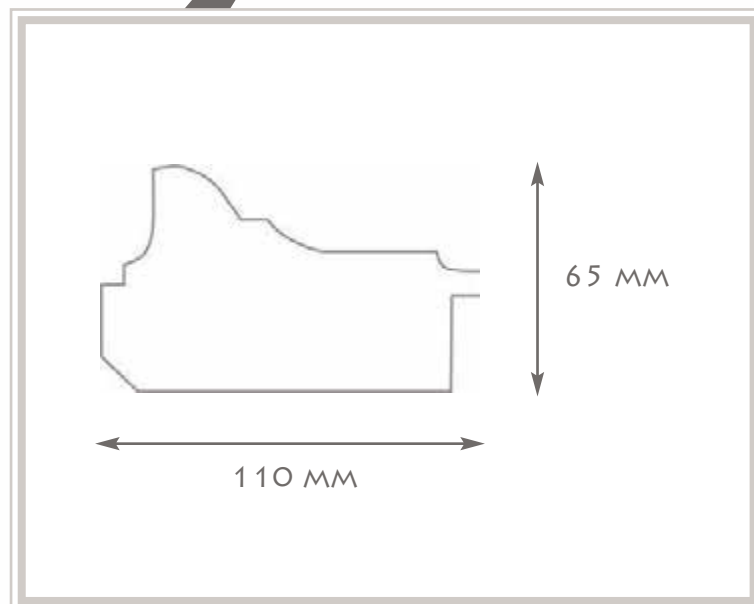

FINITURE DISPONIBILI / AVAILABLE FINISH:

1. ART. 2007 ORO / GOLD 2007
2. ART. 2007 ARGENTO / SILVER 2007

PAG.145



ART. 2008 LAV.



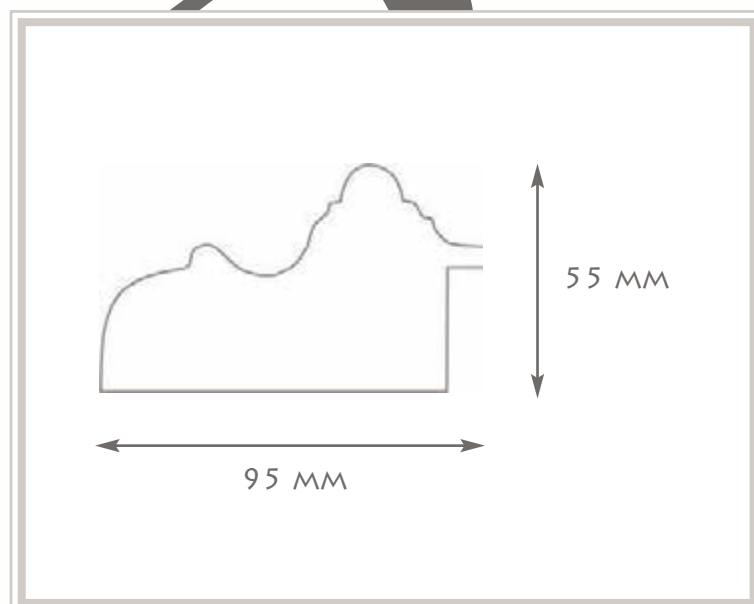

FINITURE DISPONIBILI / AVAILABLE FINISH:

1. ART. 2008 LAVORATA ORO / GOLD FASHIONED 2008
2. ART. 2008 LAVORATA ARGENTO / SILVER FASHIONED 2008

PAG.147



ART. 2009

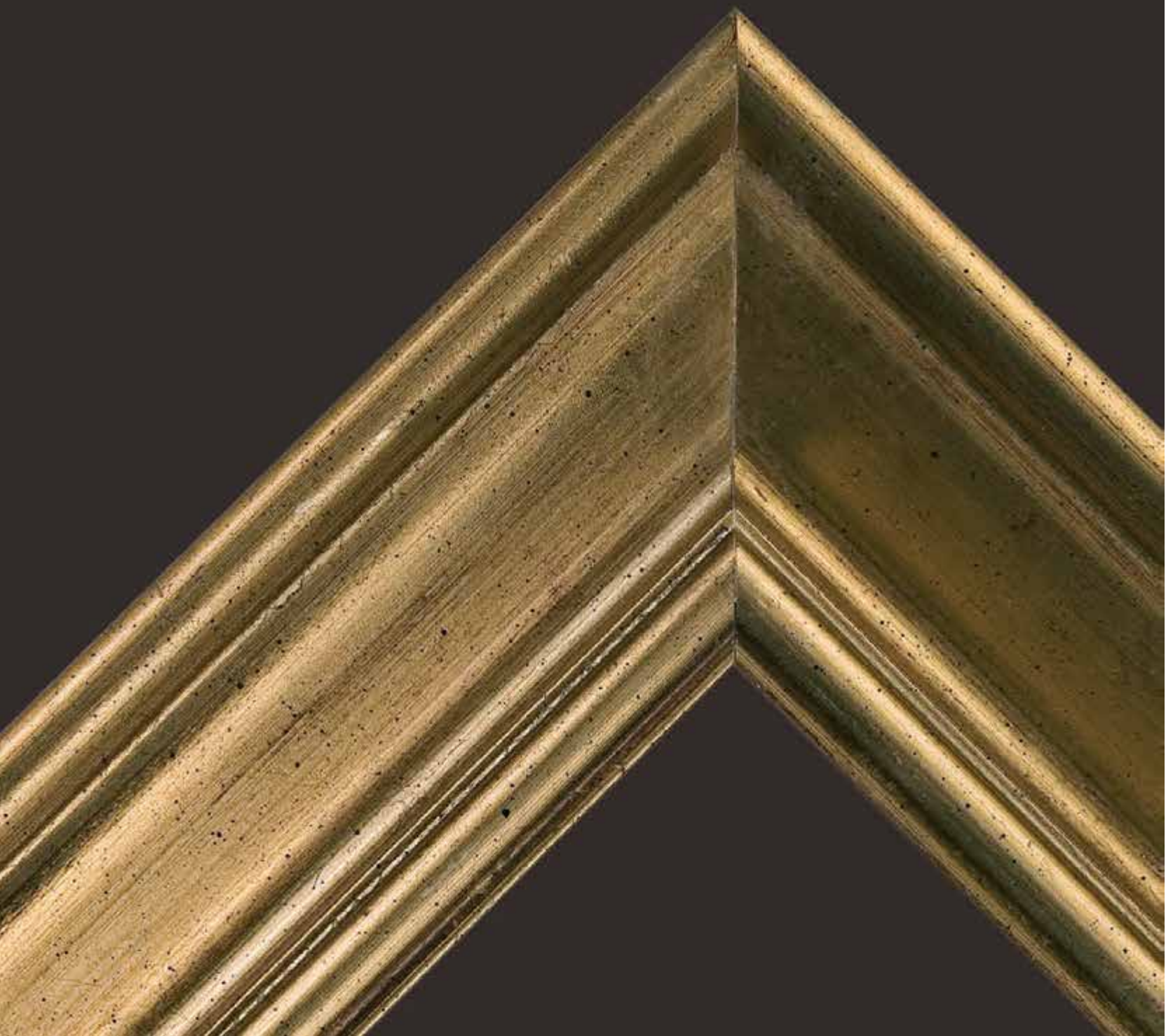

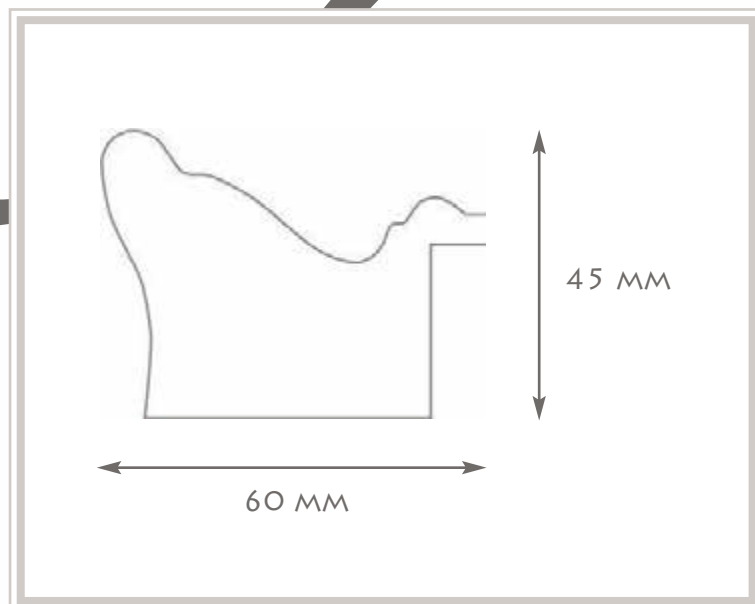

FINITURE DISPONIBILI / AVAILABLE FINISH:

PAG.149

1. ART. 2009 ORO / GOLD 2009

2. ART. 2009 ARGENTO / SILVER 2009



ART. 2010 LAV.



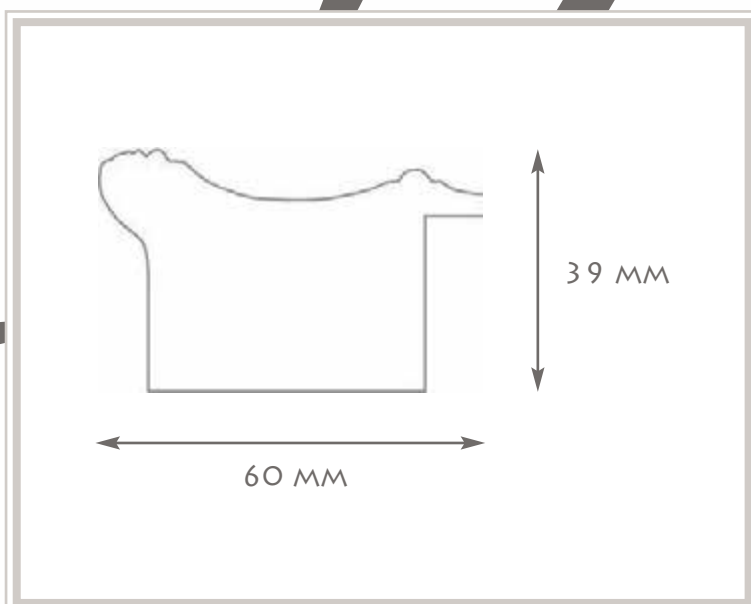

FINITURE DISPONIBILI / AVAILABLE FINISH:

2. ART. 2010 LAVORATA ARGENTO / SILVER FASHIONED 2010

1. ART. 2010 LAVORATA ORO / GOLD FASHIONED 2010

PAG.151



ART. 2010 BIS



2010 bis

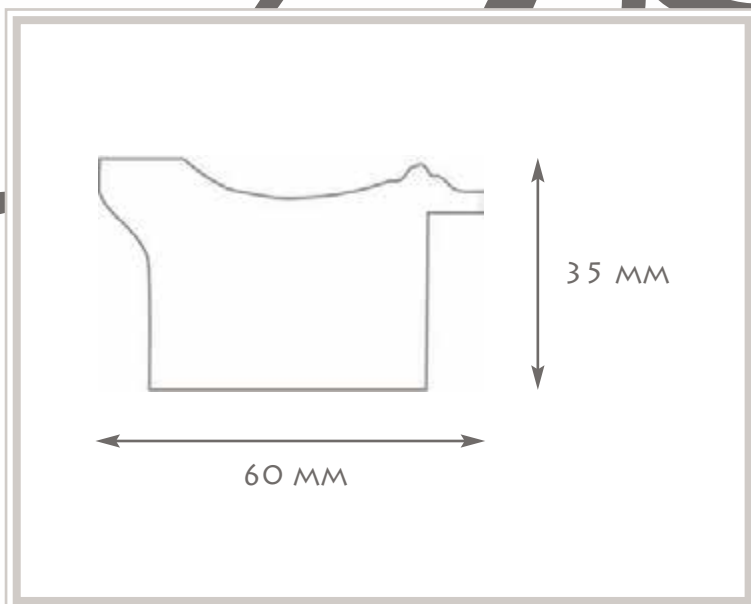

FINITURE DISPONIBILI / AVAILABLE FINISH:

PAG.153

1. ART. 2010 BIS ARGENTO / SILVER 2010 BIS



ART. A22

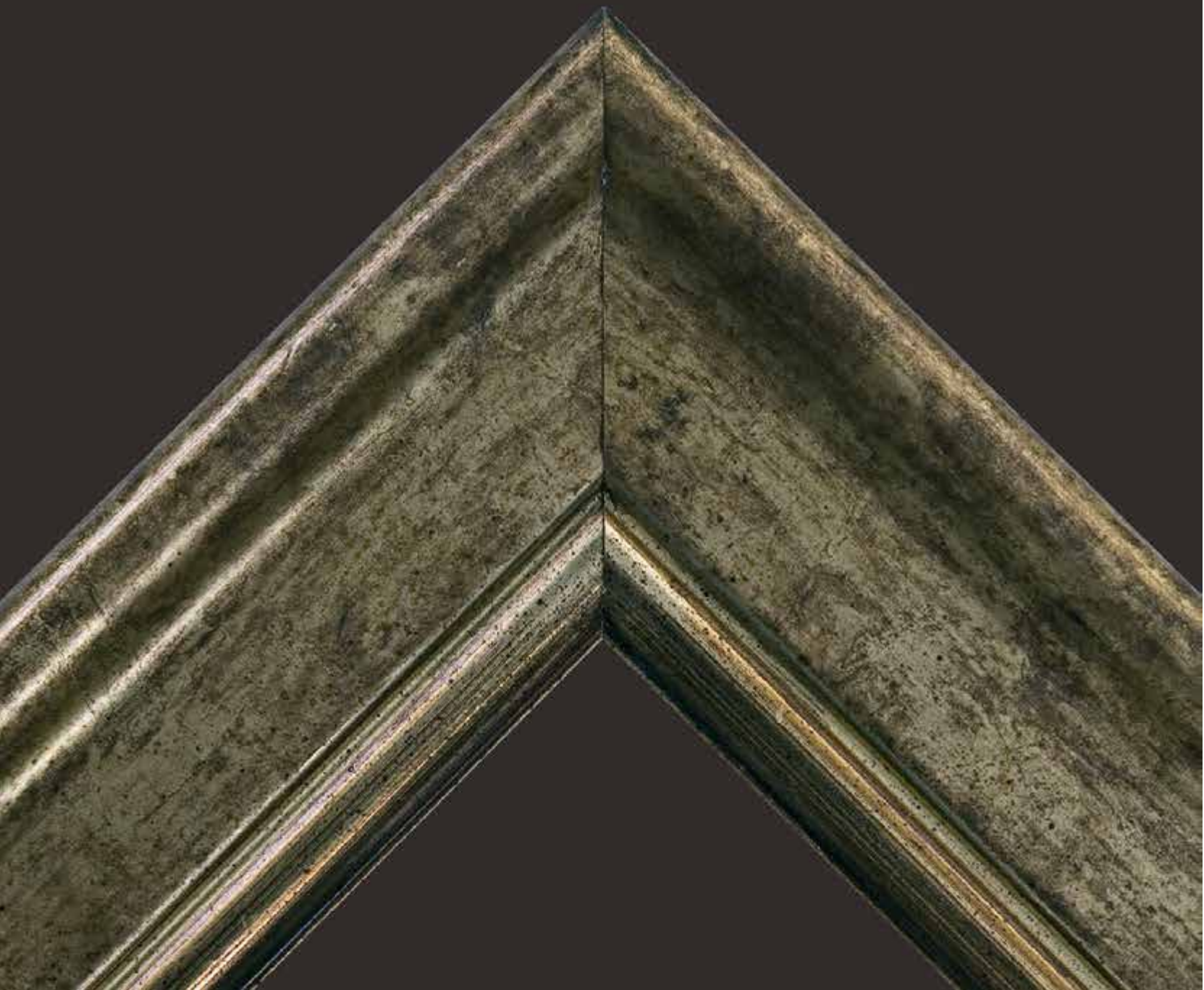

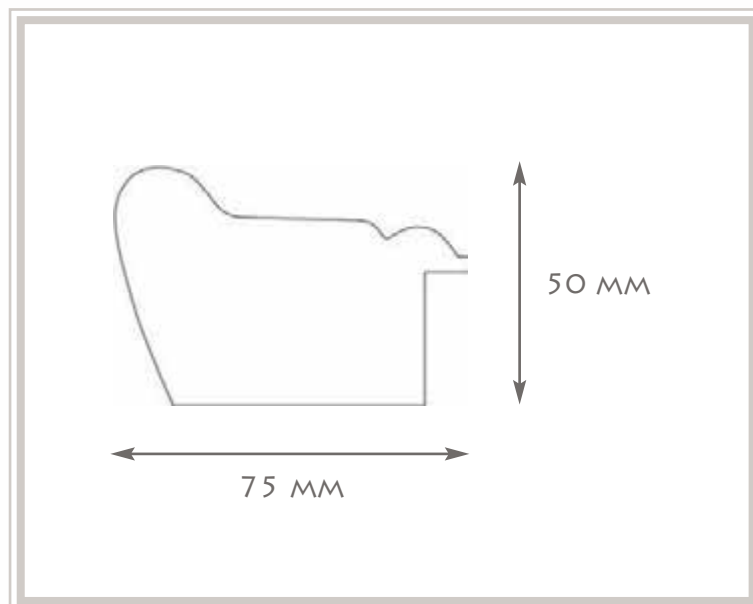

FINITURE DISPONIBILI / AVAILABLE FINISH:

1. ART. A22 ARGENTO / SILVER A22
2. ART. A22 ORO / GOLD A22

PAG.155

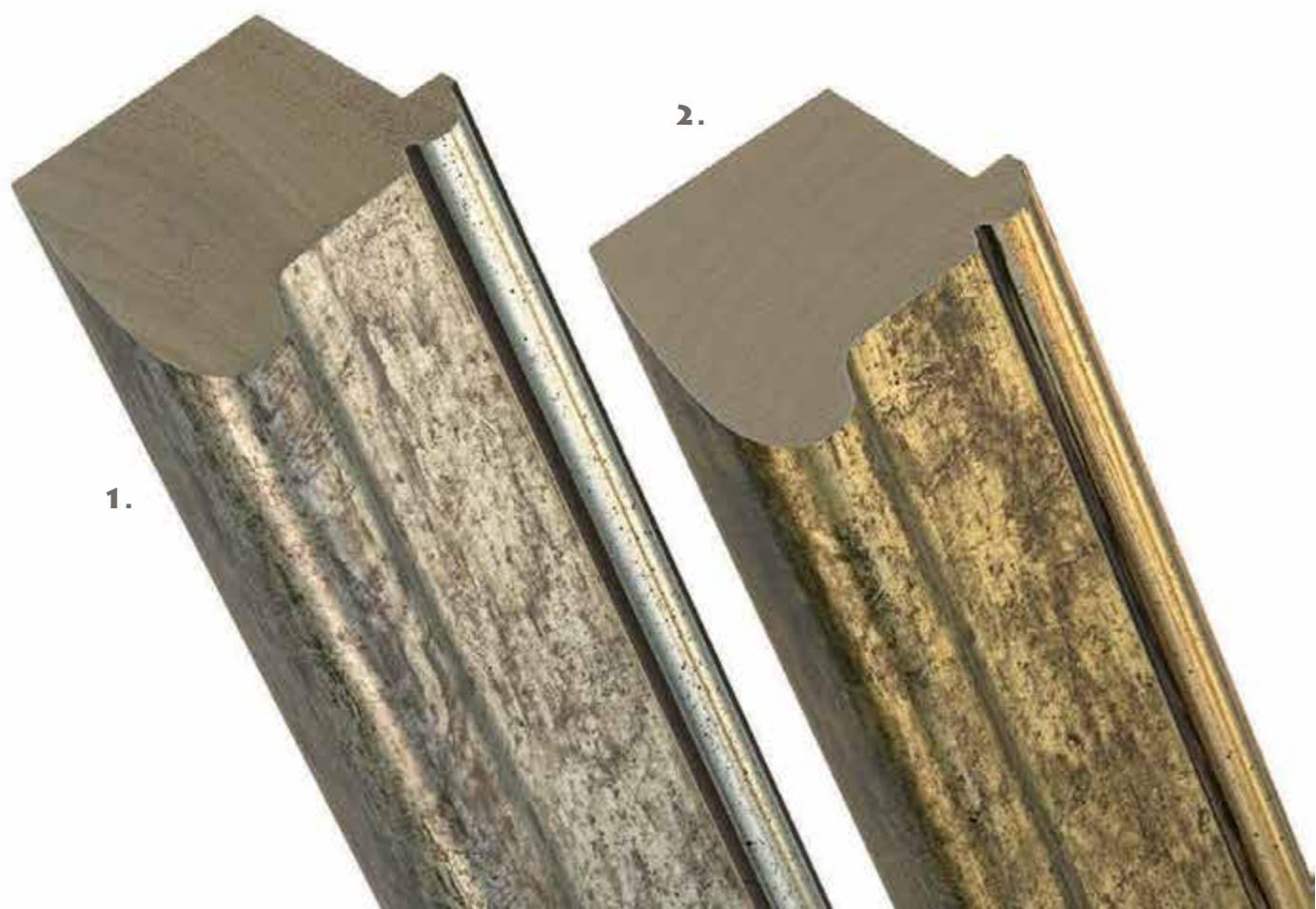

ART. A27



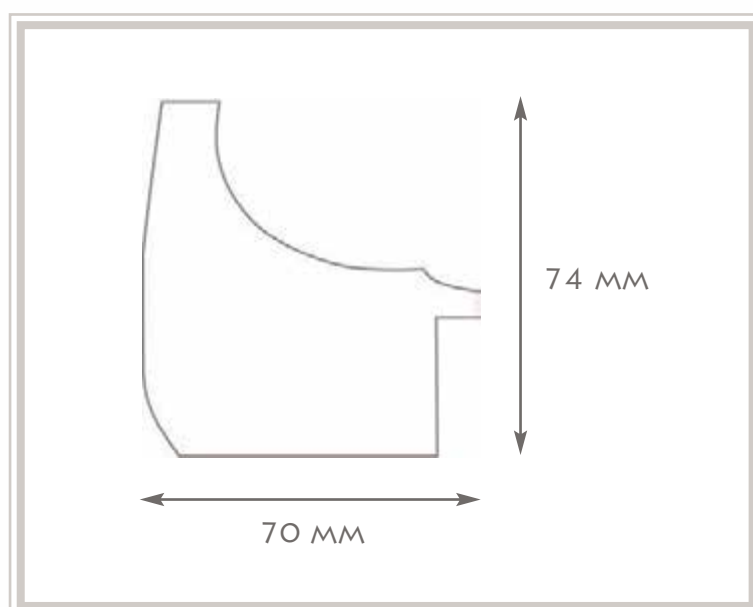

FINITURE DISPONIBILI / AVAILABLE FINISH:

1. ART. A27 AVORIO / IVORY A27

2. ART. A27 NERO / BLACK A27

2.

PAG.157

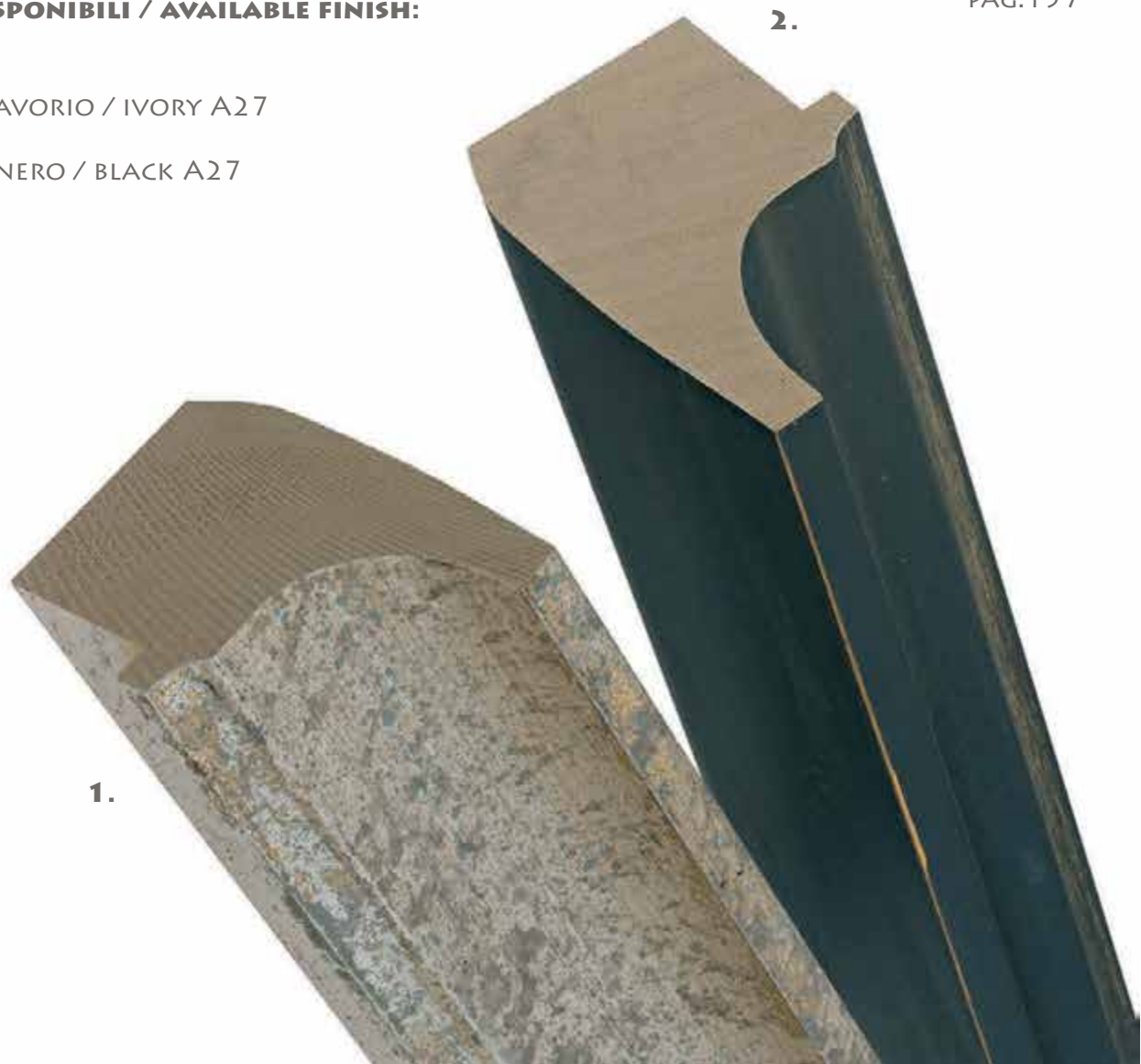

ART. A67

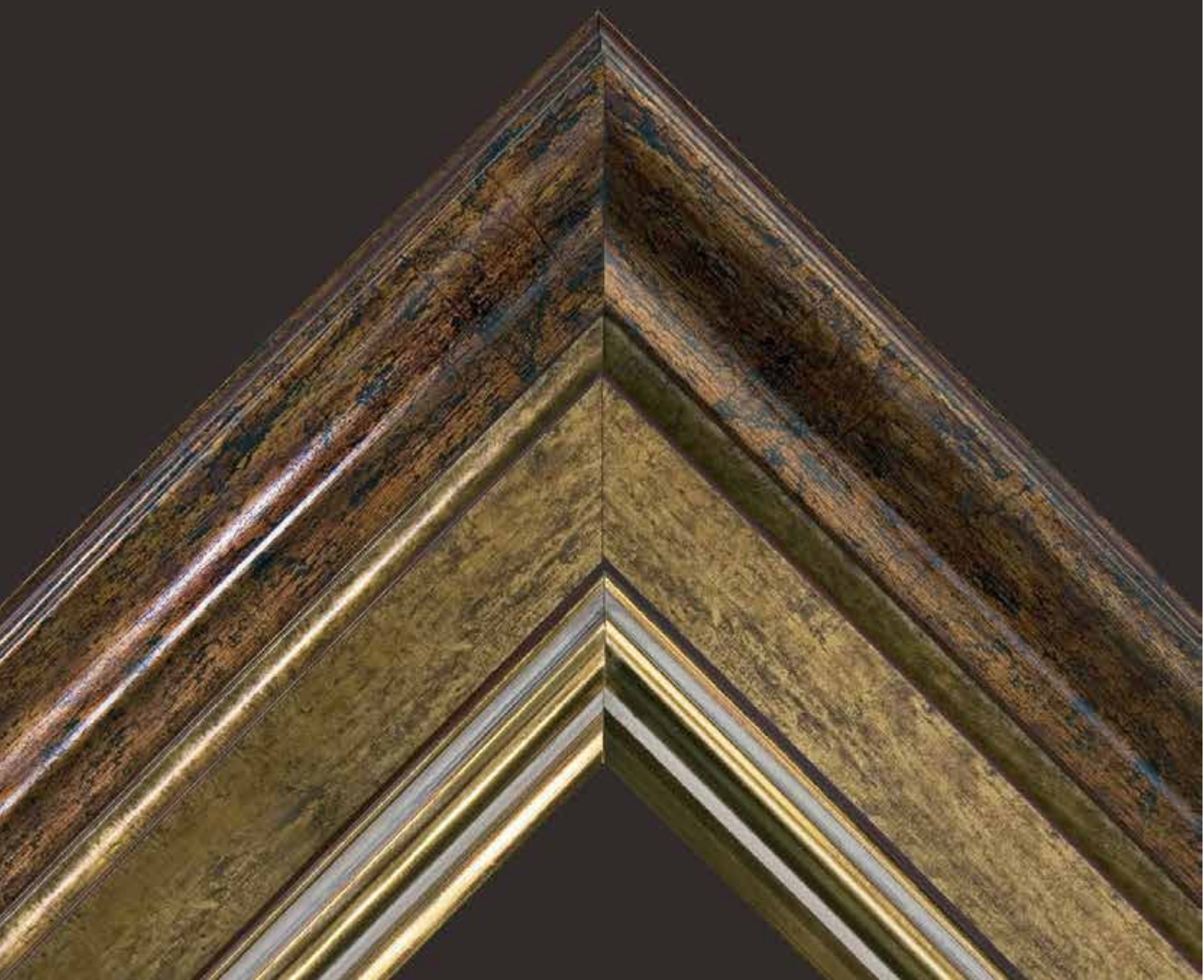

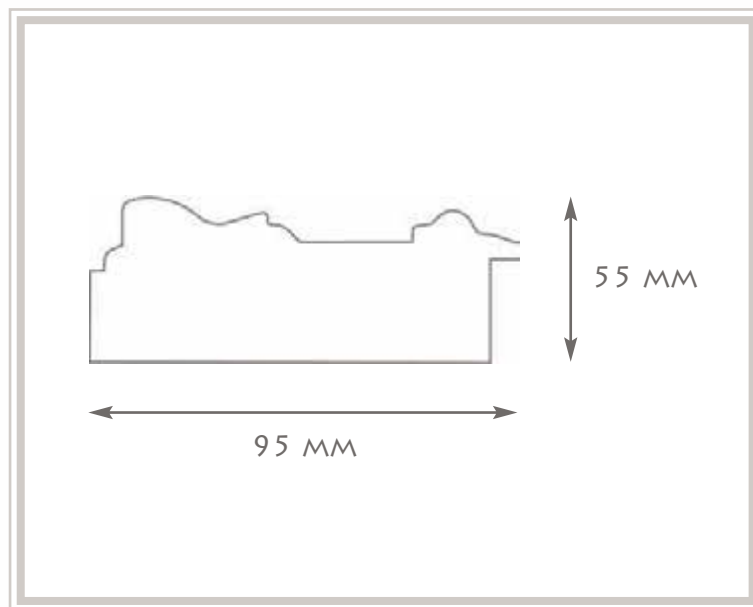

FINITURE DISPONIBILI / AVAILABLE FINISH:

1. ART. A67 NOCE / WALNUT A67



ART. A80 RID. COL.

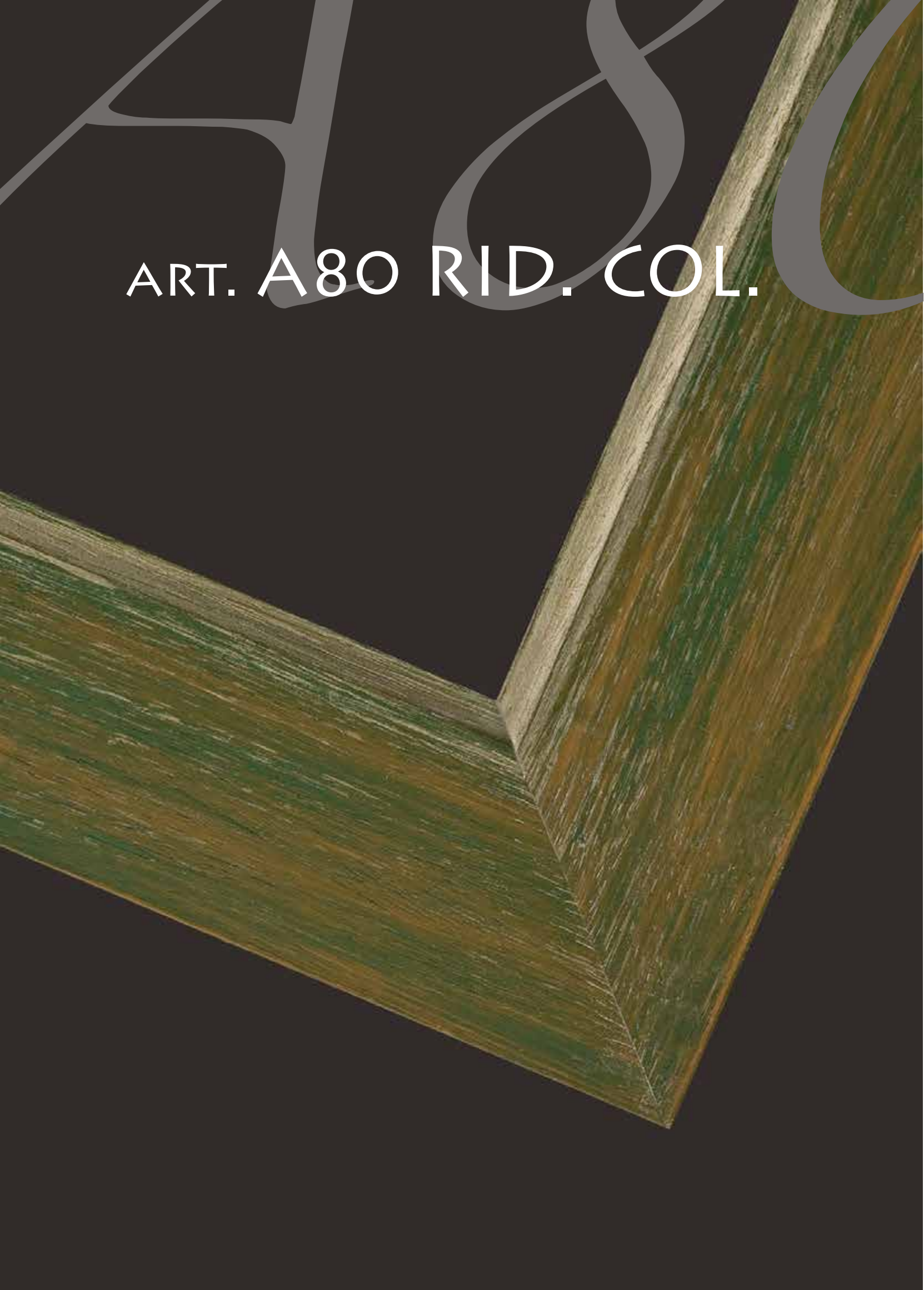

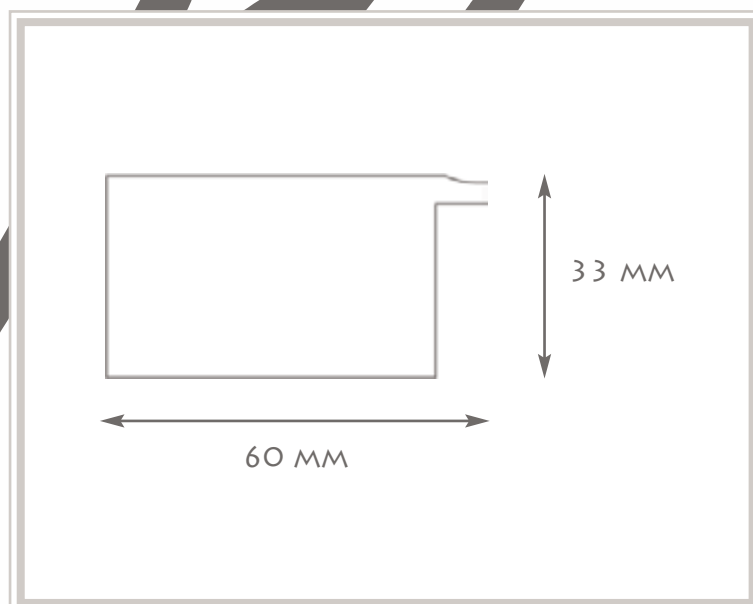

FINITURE DISPONIBILI / AVAILABLE FINISH:

1. ART. A80 RIDOTTA COLORATA BLU
/ BLUE REDUCED COLORED A80
2. ART. A80 RIDOTTA COLORATA ROSSA
/ RED REDUCED COLORED A80
3. ART. A80 RIDOTTA COLORATA VERDE
/ GREEN REDUCED COLORED A80

PAG.161

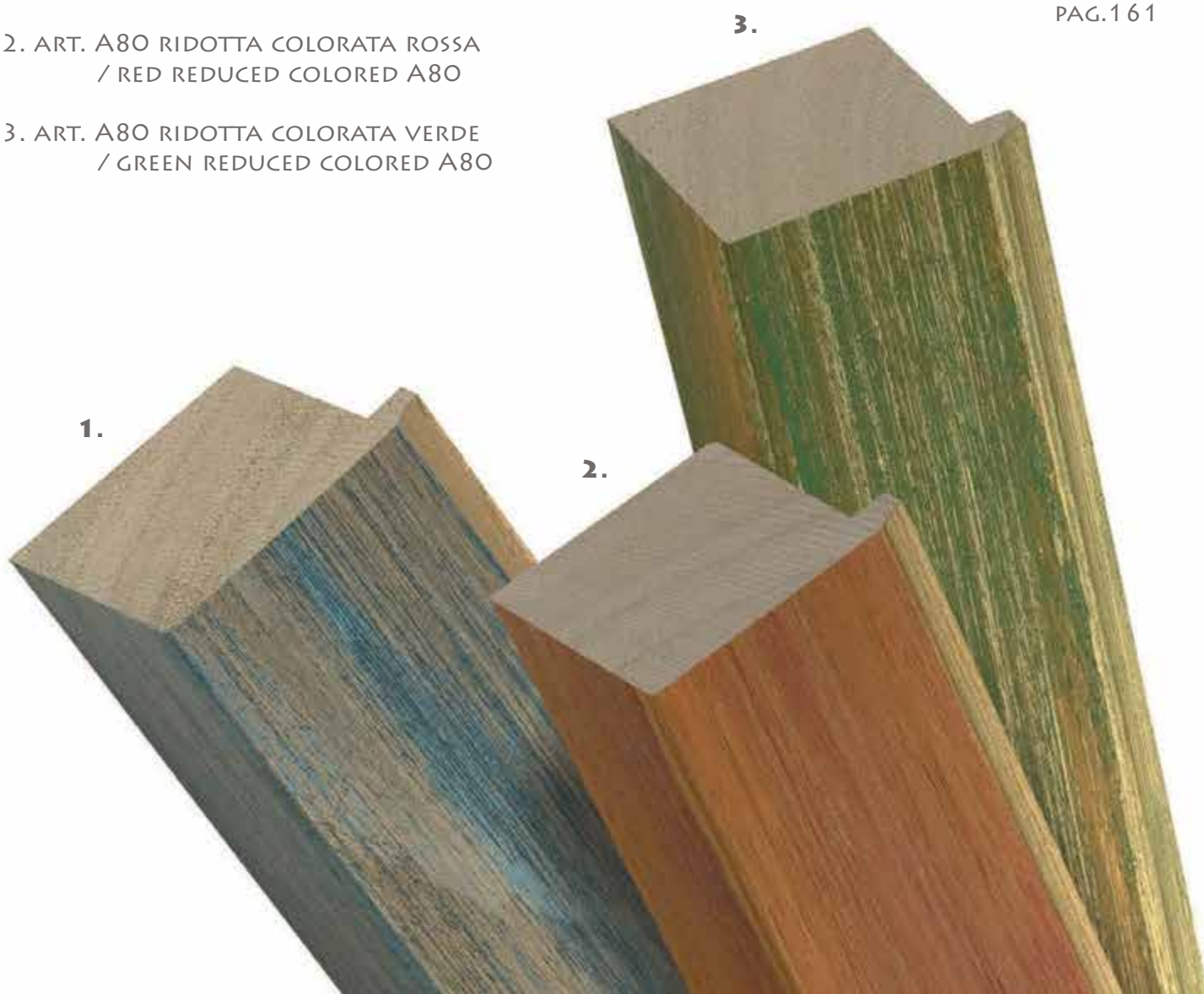

ART. F12

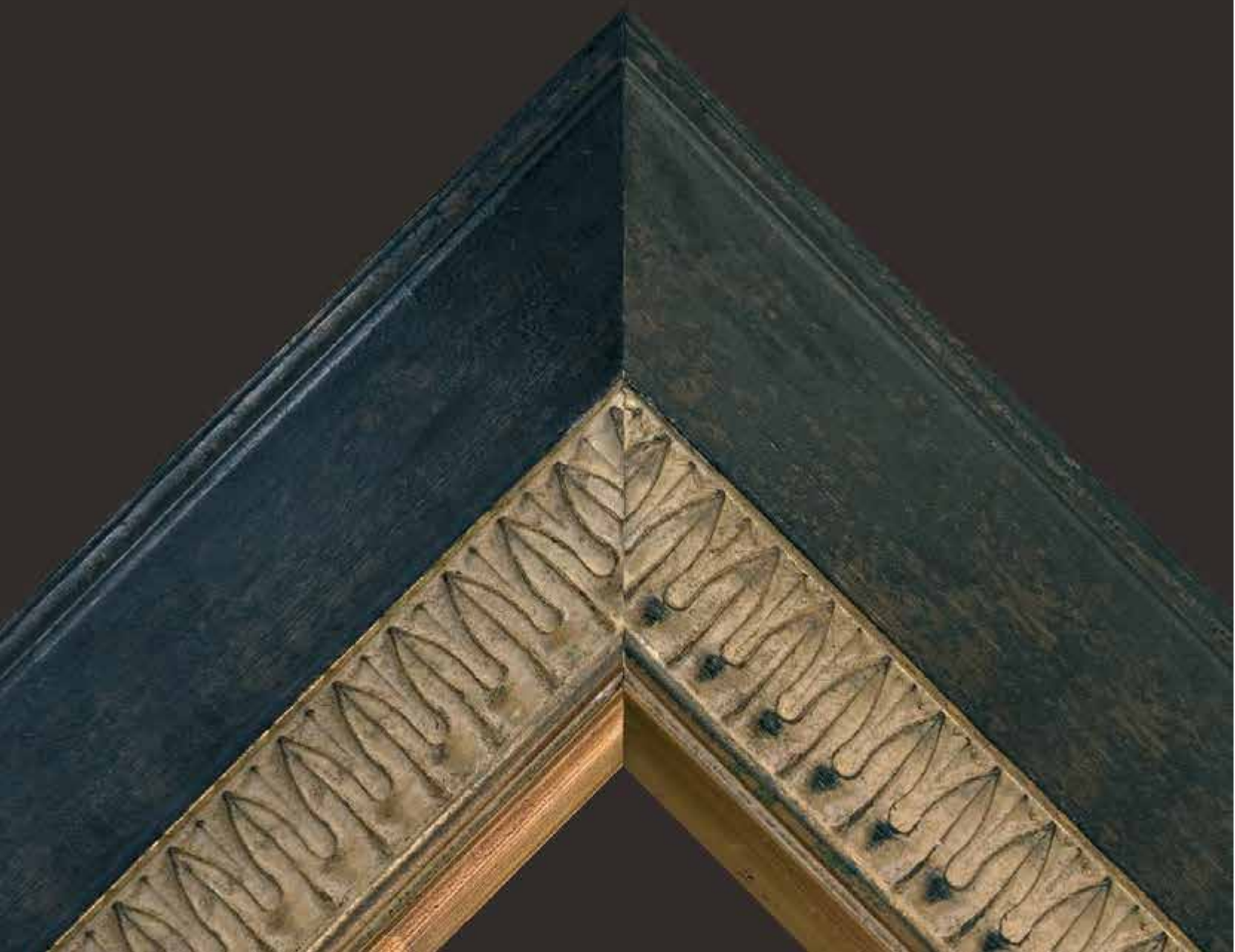

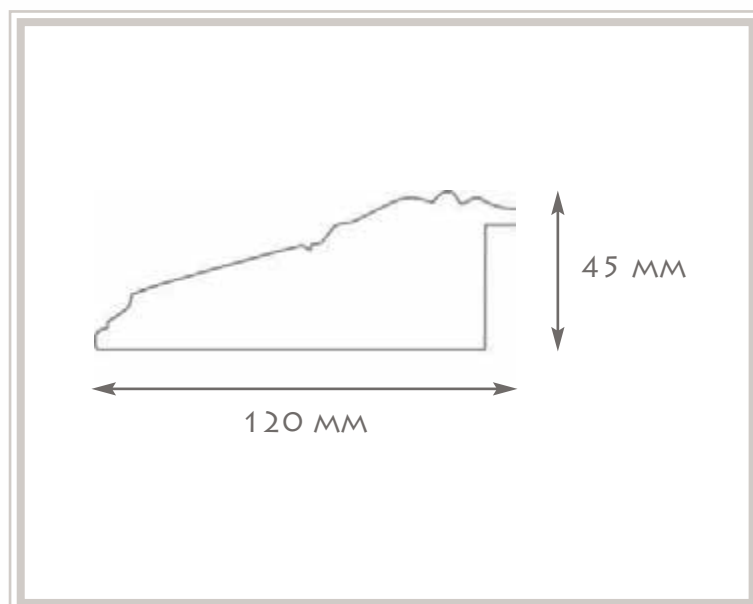

FINITURE DISPONIBILI / AVAILABLE FINISH:

1. ART. F12 ORO / GOLD F12
2. ART. F12 NERO / BLACK F12

PAG.163

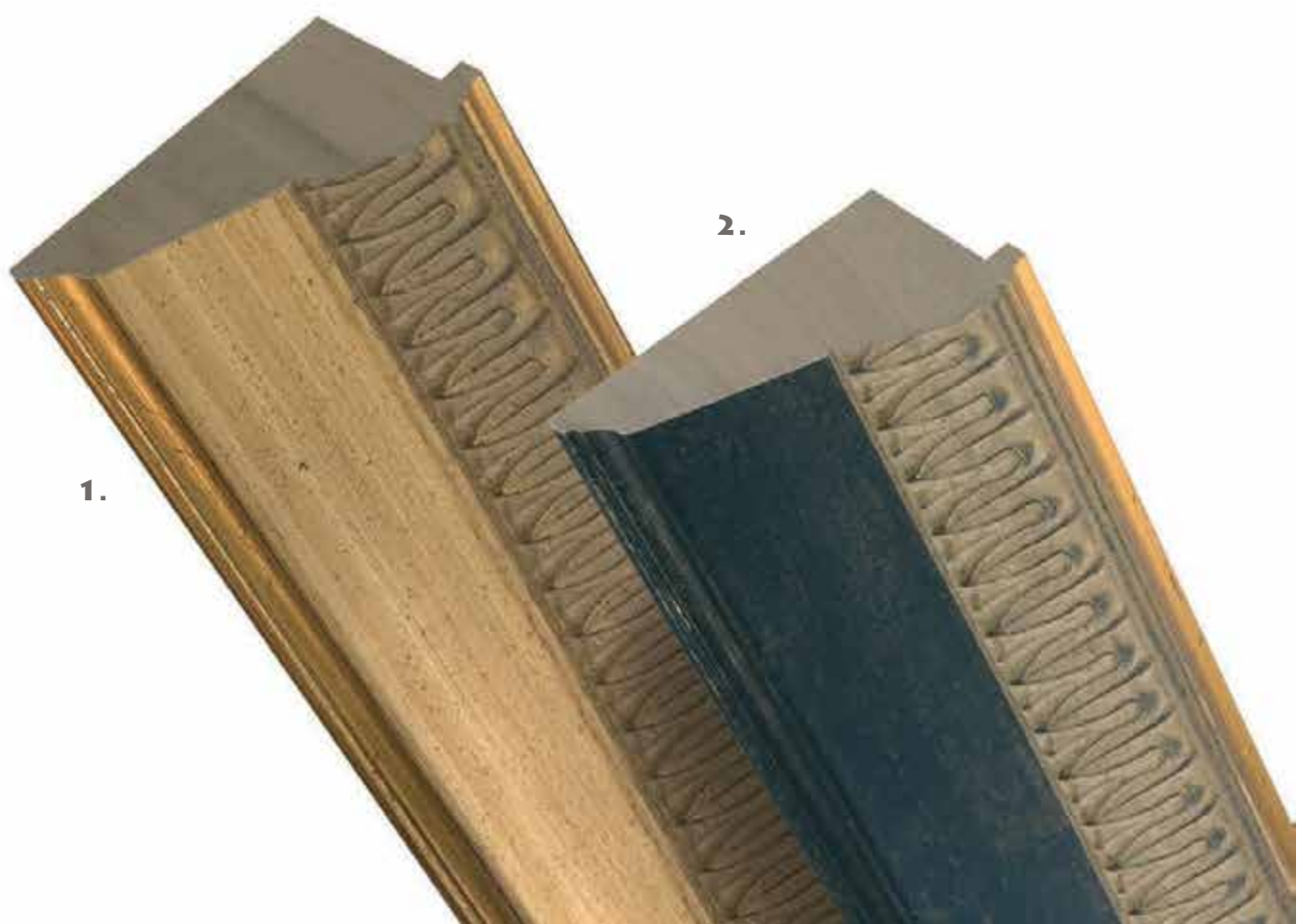

ART. G23



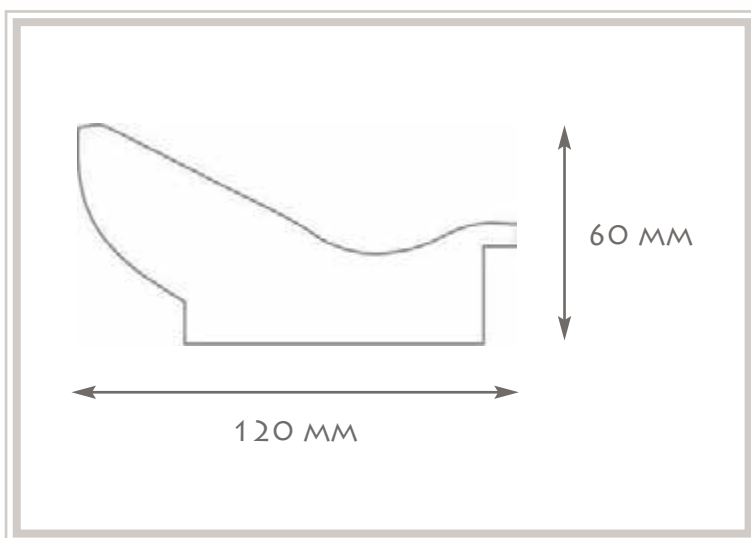

FINITURE DISPONIBILI / AVAILABLE FINISH:

1. ART. G23 BRUCIATO / BURNT G23
2. ART. G23 VERDE / GREEN G23
3. ART. G23 AVORIO ANTICO / OLD IVORY G23
4. ART. G23 AZZURRO / AZURE G23

PAG.165

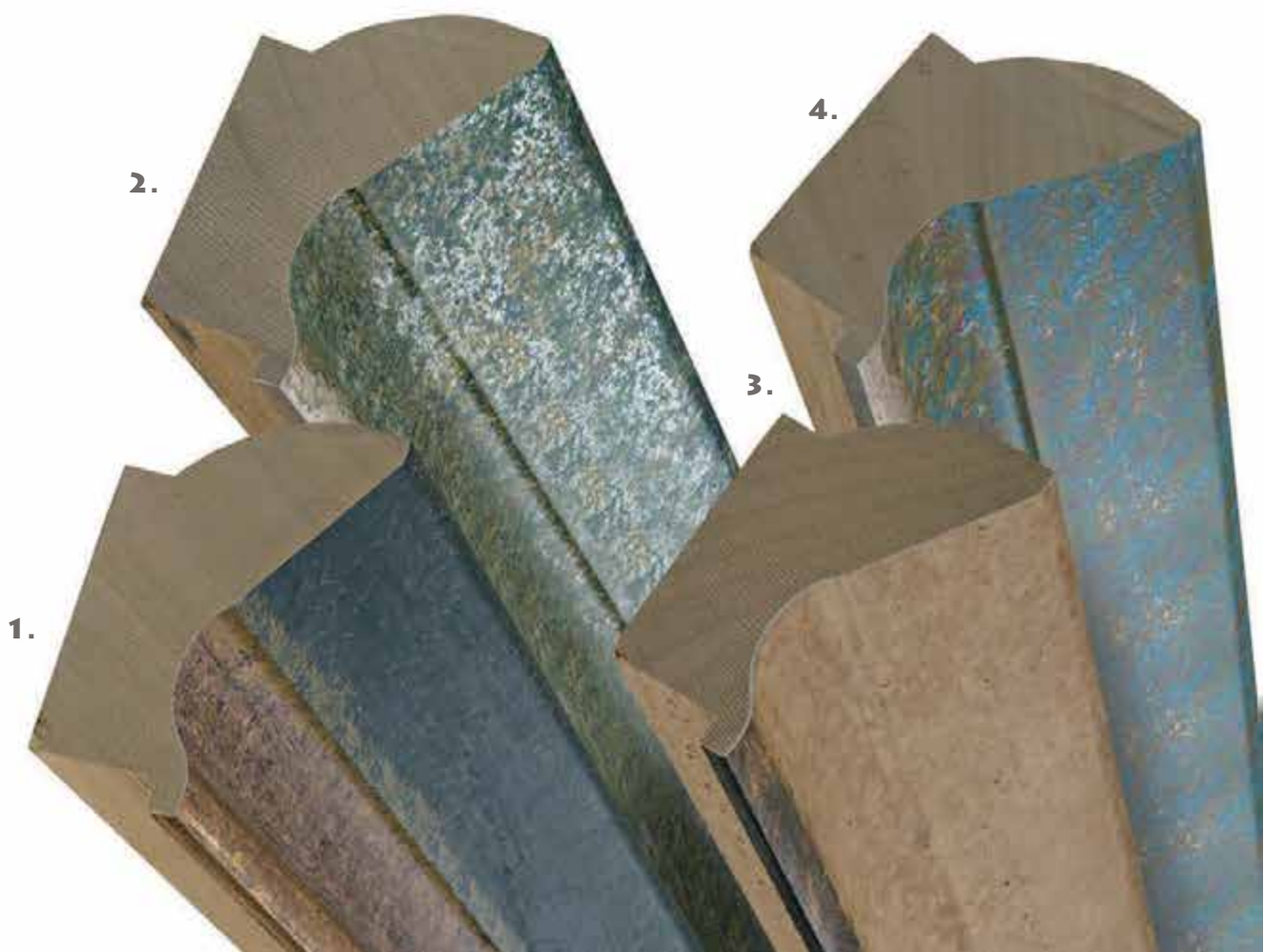

ART. G53



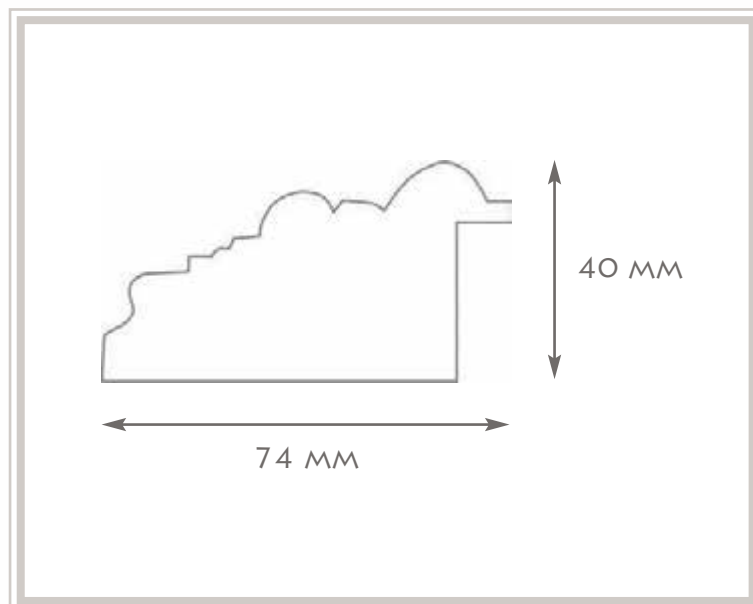

FINITURE DISPONIBILI / AVAILABLE FINISH:

PAG.167

1. ART. G53 ORO / GOLD G53

2. ART. G53 ARGENTO / SILVER G53



ART. L91

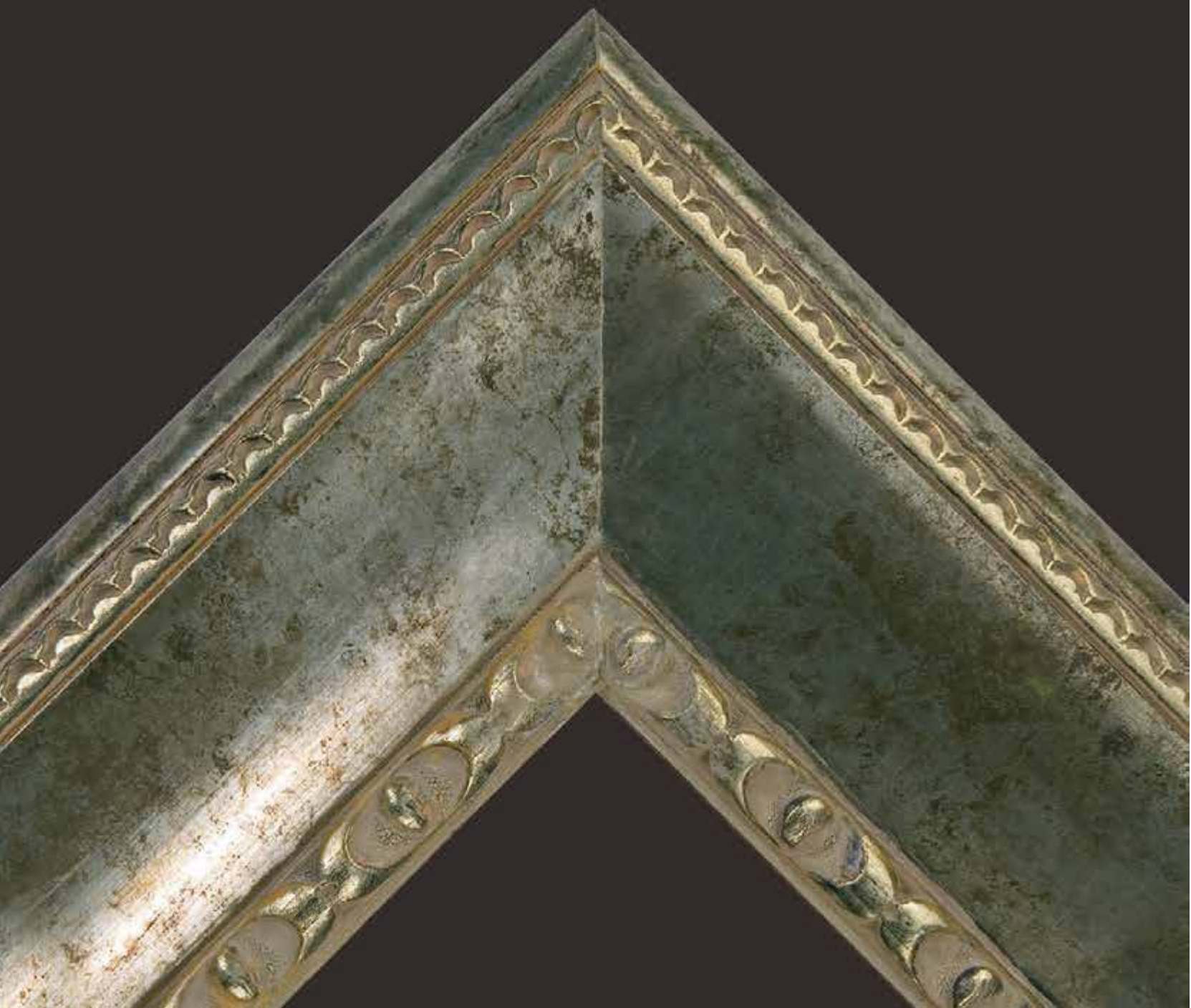

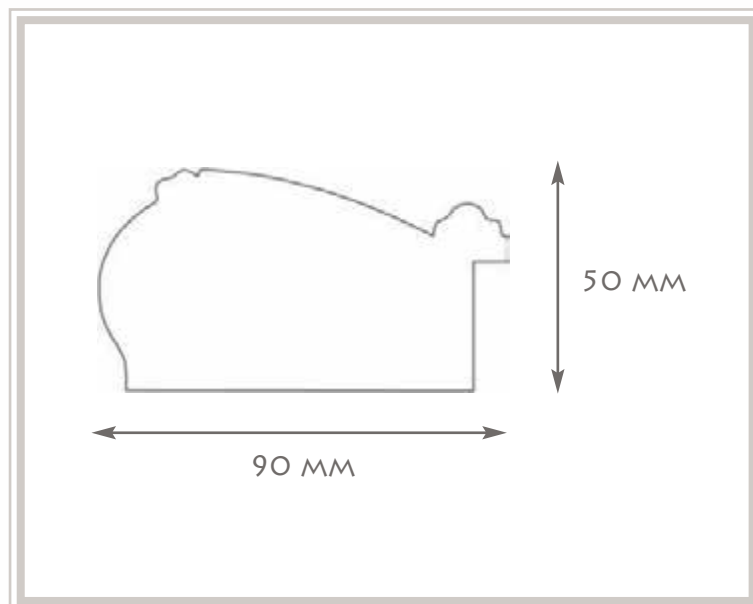

FINITURE DISPONIBILI / AVAILABLE FINISH:

PAG.169

1. ART. L91 ARGENTO / SILVER L91

2. ART. L91 ORO / GOLD L91

2.



ART. MC6

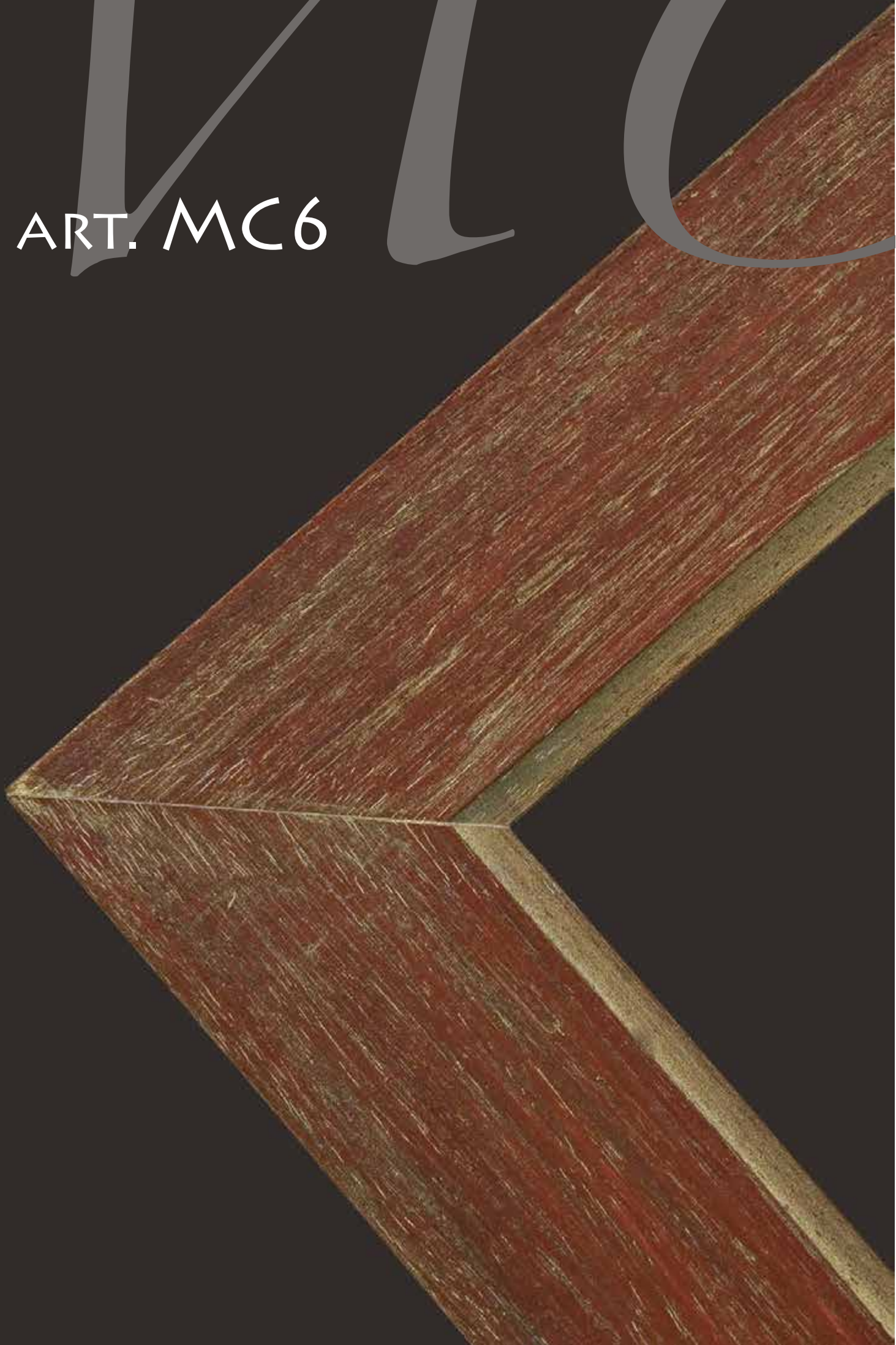

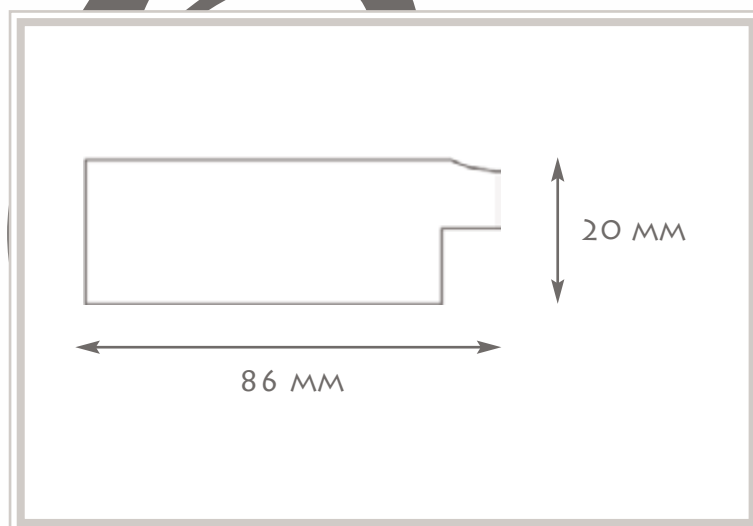

FINITURE DISPONIBILI / AVAILABLE FINISH:

1. ART. MC6 AVORIO / IVORY MC6
2. ART. MC6 WENGÉ / WENGÉ MC6
3. ART. MC6 ROSSO / RED MC6
4. ART. MC6 BLU / BLUE MC6

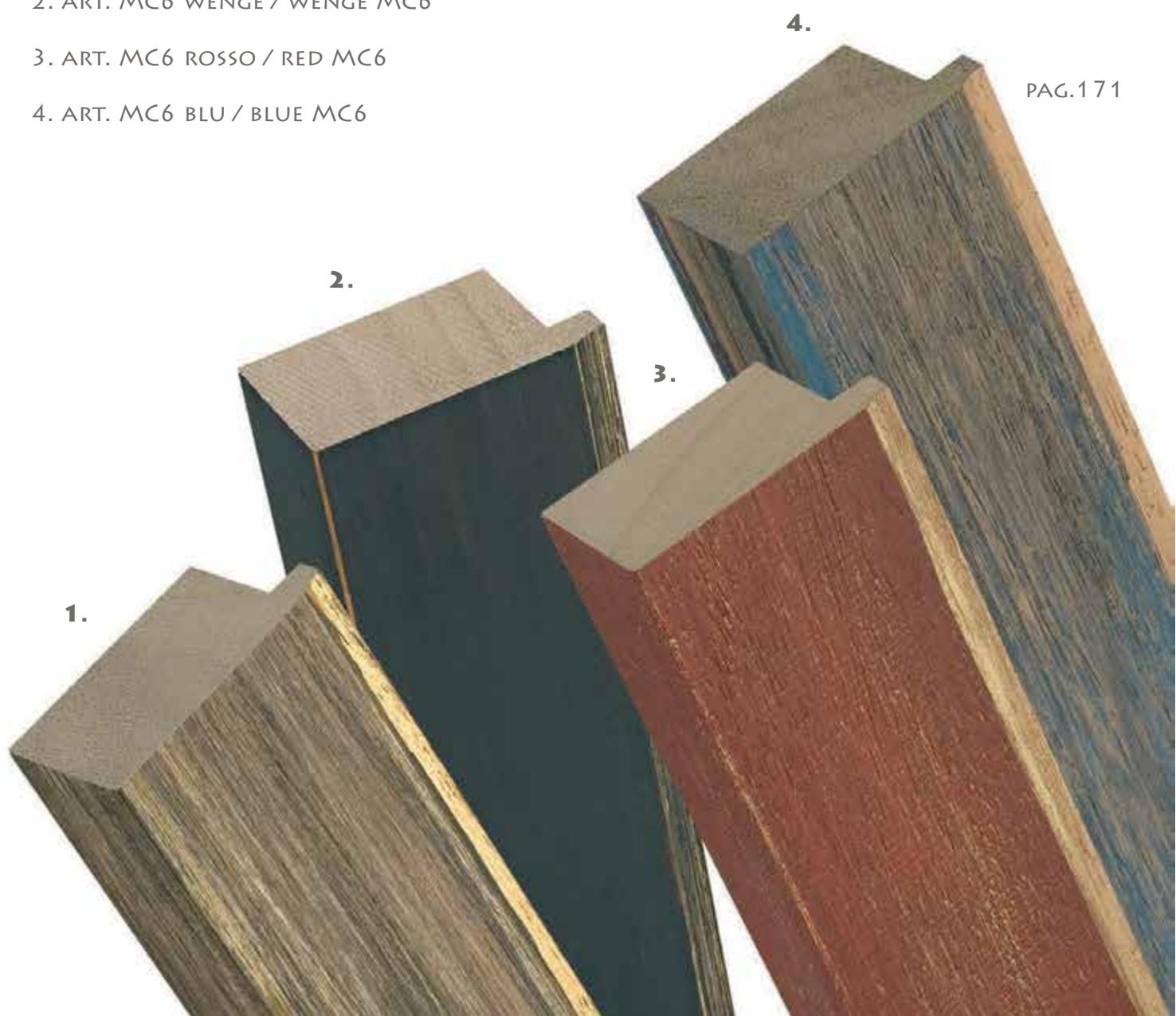

ART. P8



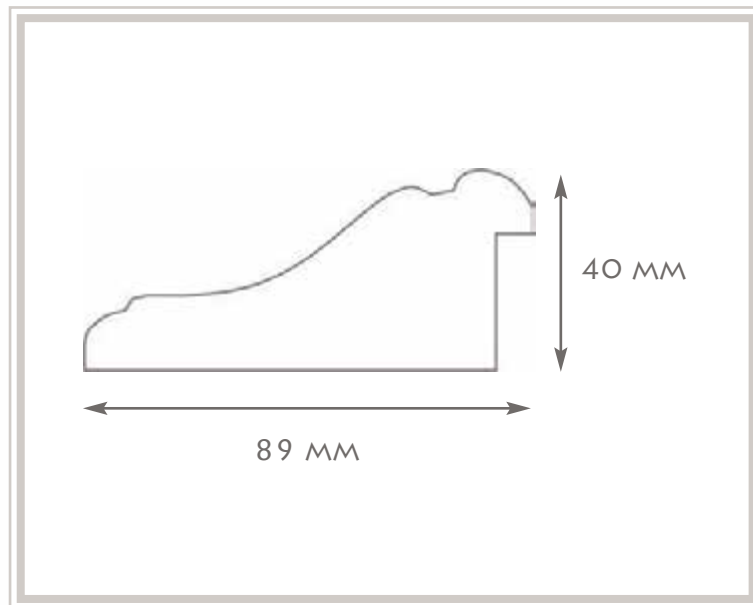

FINITURE DISPONIBILI / AVAILABLE FINISH:

PAG.173

1. ART. P8 ARGENTO / SILVER P8

2. ART. P8 ORO / GOLD P8

2.

1.



ART. P66

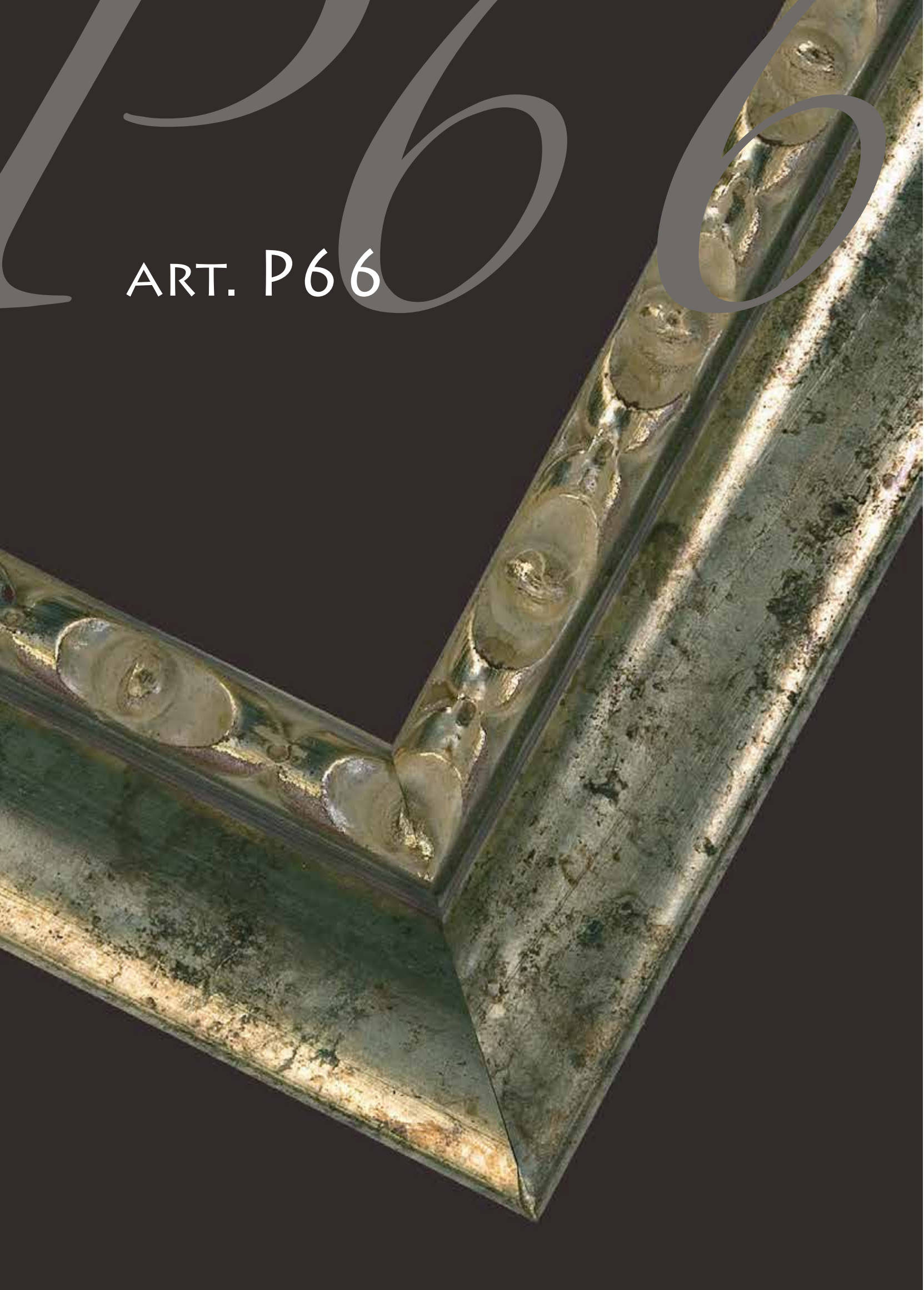

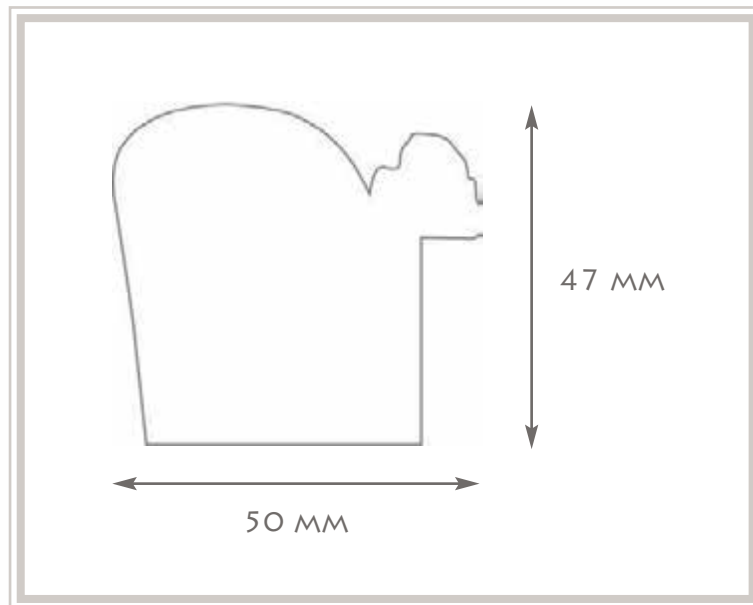

FINITURE DISPONIBILI / AVAILABLE FINISH:

PAG.175

1. ART. P66 ARGENTO / SILVER P66

2. ART. P66 ORO / GOLD P66



ART. RIC/O8

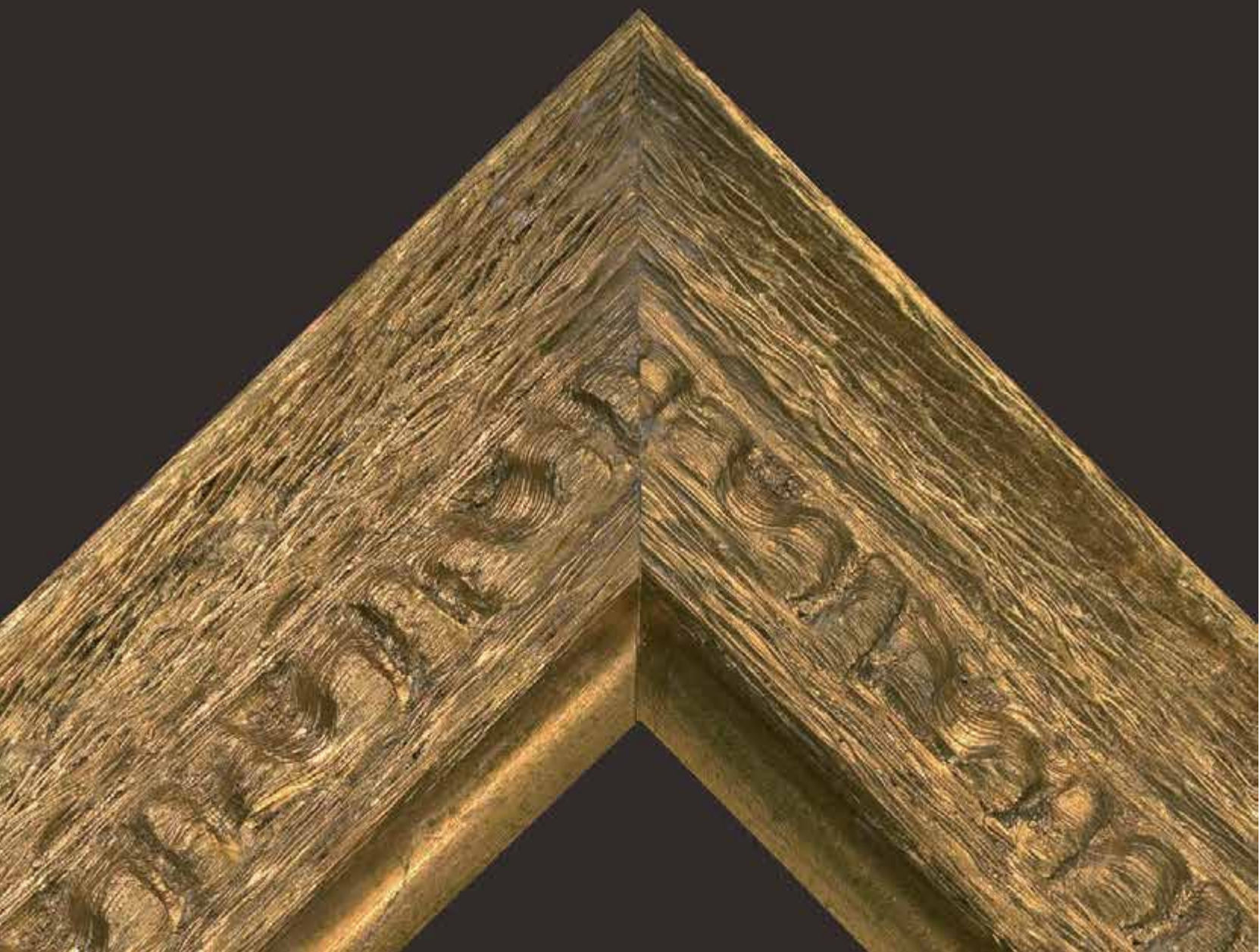

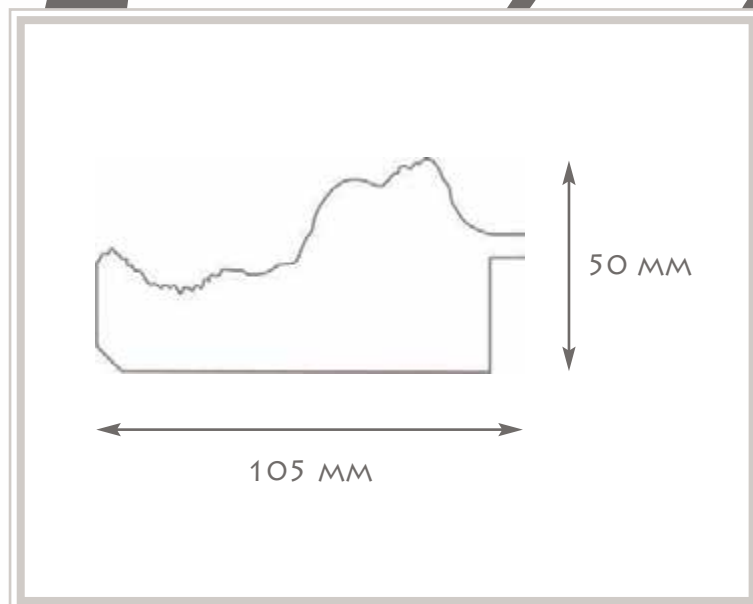

FINITURE DISPONIBILI / AVAILABLE FINISH:

PAG.177

1. ART. RIC/O8 ORO / GOLD RIC/O8



ART. S56

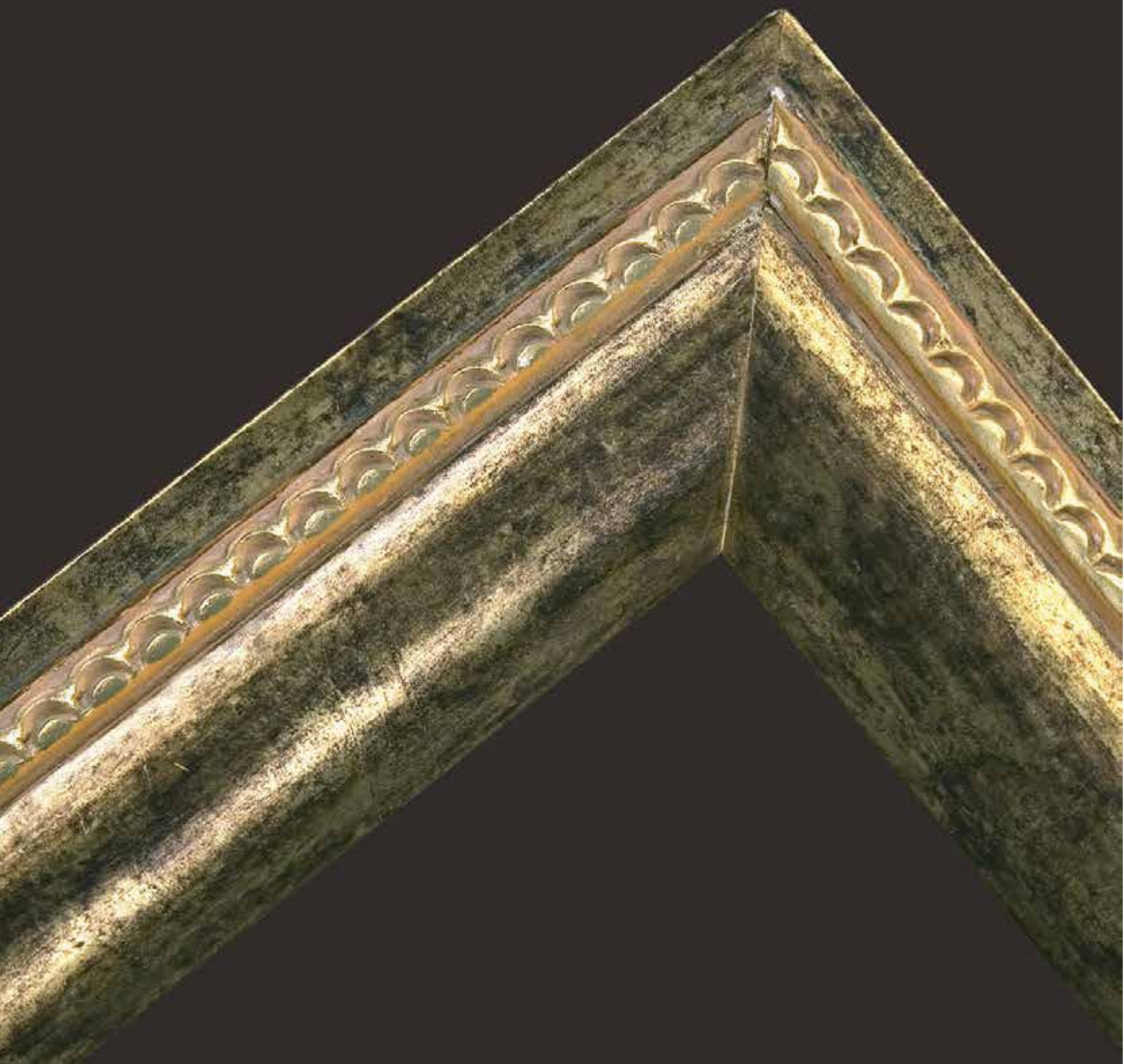

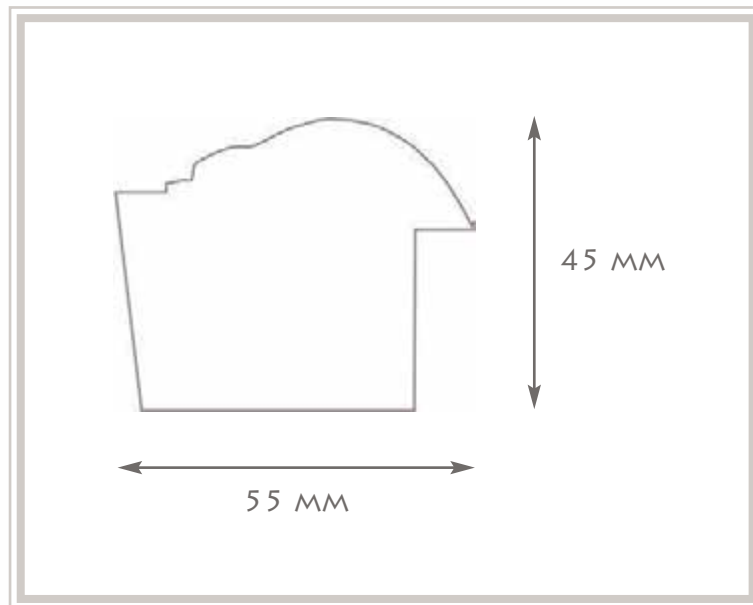

FINITURE DISPONIBILI/AVAILABLE FINISH:

PAG.179

1. ART. S56 ORO / GOLD S56

2. ART. S56 ARGENTO / SILVER S56



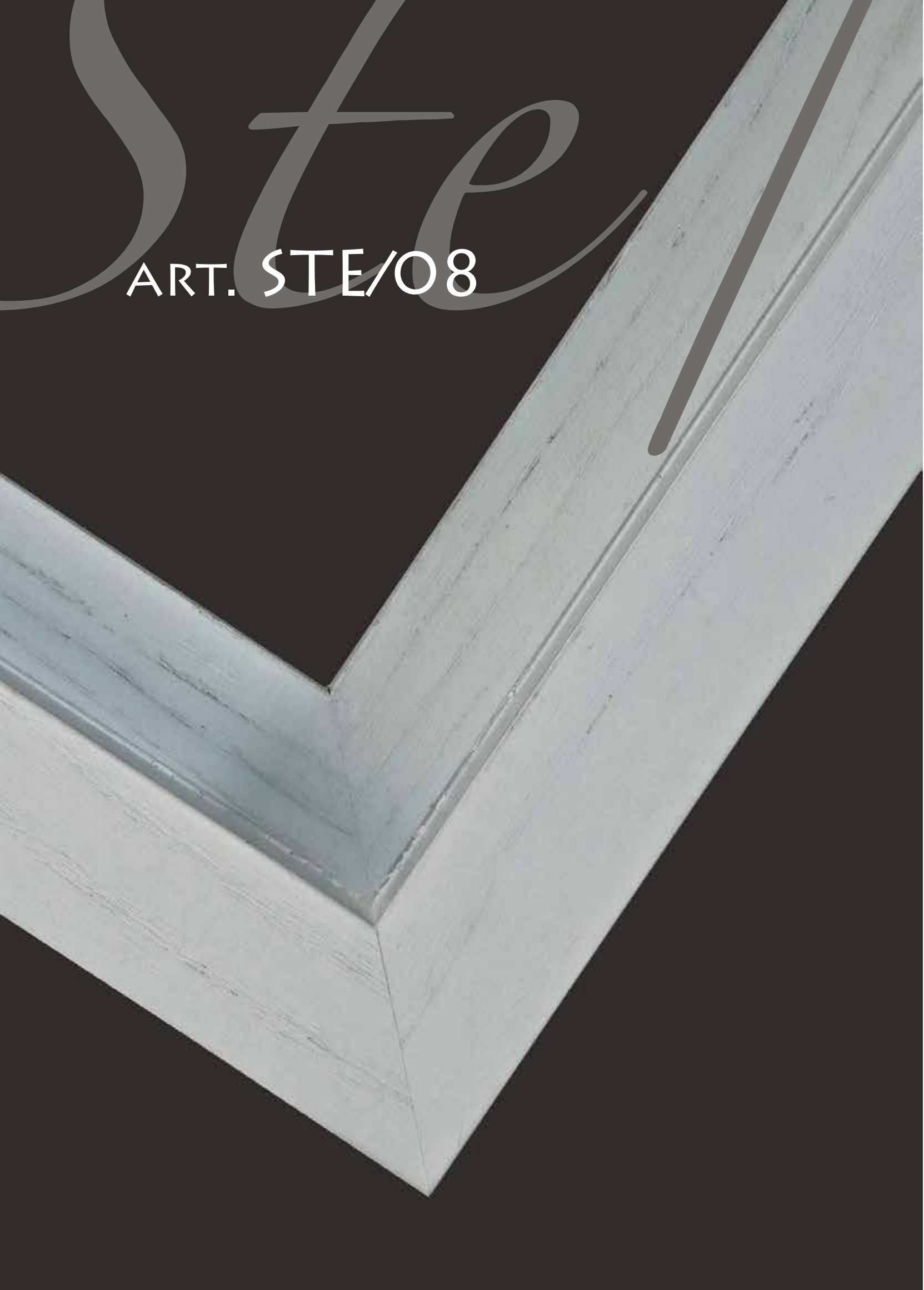

ART. STE/08

Ste

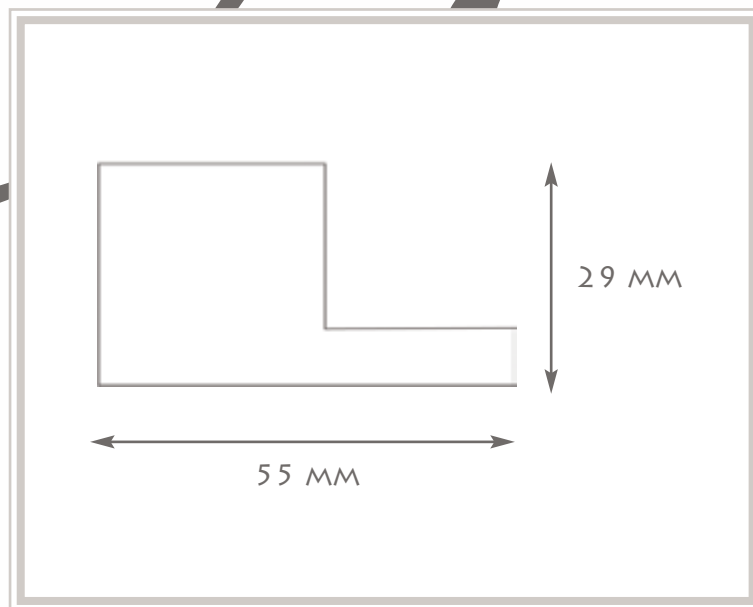

FINITURE DISPONIBILI / AVAILABLE FINISH:

1. ART. STE/O8 NERO / BLACK STE/O8
2. ART. STE/O8 BIANCO / WHITE STE/O8

2.

PAG.181

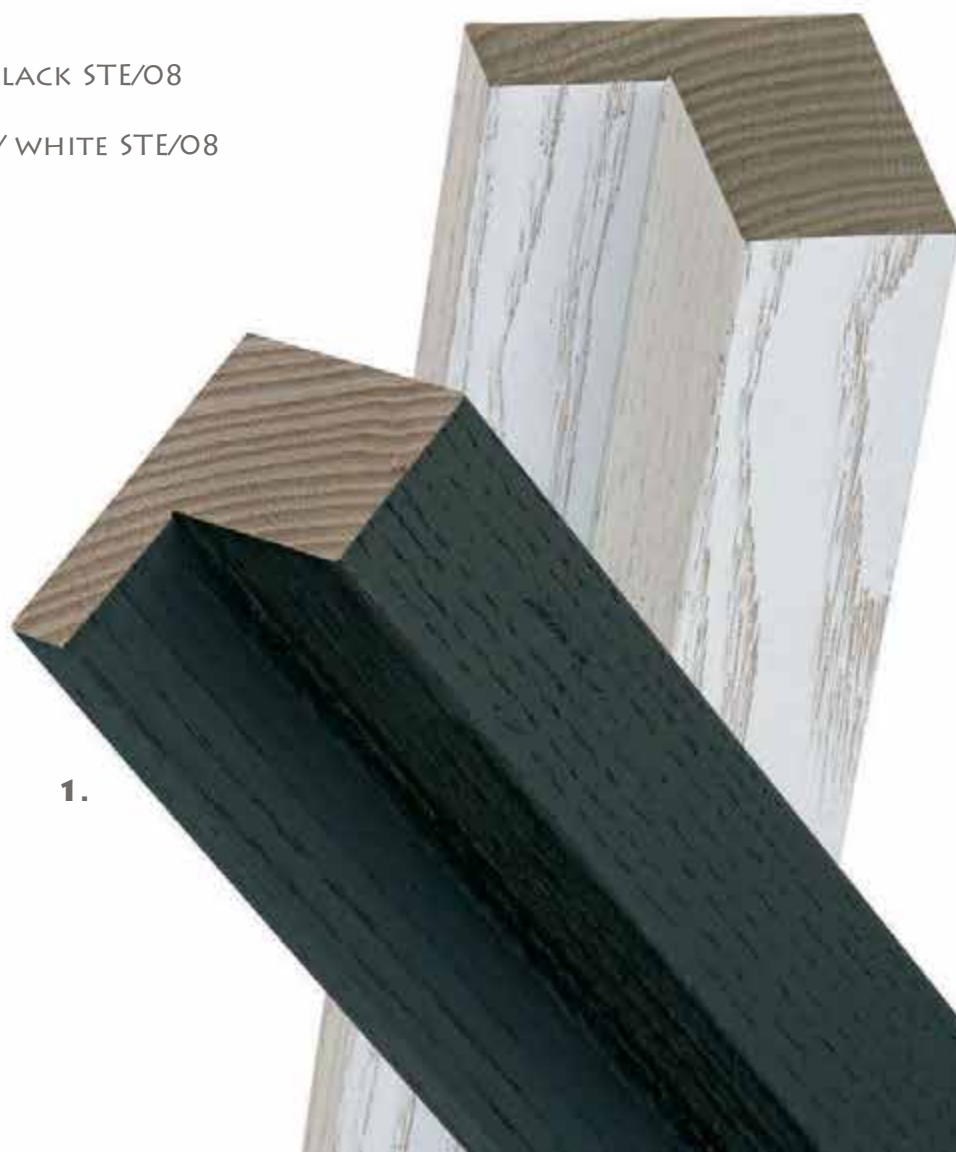

1.

INDICE

PAG.2 FALPA

PAG.4 INTRODUZIONE

PAG.6 CORNICI ANTICHITÀ - FINITURA ARTIGIANALE

PAG.6 BASCHENIS

PAG.10 BELLINI

PAG.14 BOTTICELLI

PAG.18 CANALETTO

PAG.22 CARAVAGGIO

PAG.26 CORREGGIO

PAG.30 DEGAS

PAG.34 KLIMT

PAG.38 LEONARDO

PAG.42 LIBERTY

PAG.46 LOTTO

PAG.50 LOVERINI

PAG.54 MONET

PAG.58 PICCIO

PAG.62 RENOIR

PAG.66 RUBENS

PAG.70 SOLE

PAG.74 TINTORETTO

PAG.78 TIZIANO

PAG.82 VAN GOGH

PAG.86 VELASQUEZ

PAG.90 ZOR

PAG.94 ARGENTO VERO E ORO ZECCHINO



PAG.100

CORNICI STANDARD

PAG.100	DE PISIS
PAG.102	98
PAG.104	100
PAG.106	110 LAV
PAG.108	196
PAG.110	207
PAG.112	208
PAG.114	258 LAV
PAG.116	319
PAG.118	320
PAG.120	340
PAG.122	350
PAG.124	360
PAG.126	400
PAG.128	600
PAG.130	650
PAG.132	673
PAG.134	745
PAG.136	746 BIS
PAG.138	950
PAG.140	2003
PAG.142	2003 LAV
PAG.144	2007
PAG.146	2008
PAG.148	2009
PAG.150	2010 LAV
PAG.152	2010 BIS

PAG.154

A22

PAG.156	A27
PAG.158	A67
PAG.160	A80 RID COL
PAG.162	F12
PAG.164	G23
PAG.166	G53
PAG.168	L91
PAG.170	MC6
PAG.172	P8
PAG.174	P66
PAG.176	RIC/O8
PAG.178	S56
PAG.180	STE/O8

**PER GLI ALLESTIMENTI NEL CASTELLO DI CAVERNAGO (BG)
SI RINGRAZIANO:**

PRINCIPE CARLOS GONZAGA

SILVIO LONGHI

MOBILI D'ARTE CESARINO ROZZONI

VINCENZO RANGHETTI

MAESTRO GIORGIO ZAMBO (CHITARRA)

GIACOMO LEONE (BATTERIA)

PASQUALE SCARPATO (CONTRABBASSO)

DIREZIONE ARTISTICA

MARKAB INSIDE - CREATIVITA' AD ARTE - TORINO

GRAPHIC DESIGN

LAURA GIAI BAUDISSARD

SERVIZIO FOTOGRAFICO E RIPRODUZIONE DIPINTI

VALTER FIORIO

© IMMAGINI

FALPA - SERIATE (BG)

FINITO DI STAMPARE NEL MESE DI DICEMBRE 2008
PRESSO TECNOGRAFF - S. PAOLO D'ARGON (BG)

